

AXIS Q7900 Rack Installation Guide

This installation guide describes the hardware installation of the AXIS Q7900, which can hold up to 14 Axis video encoder blades. To install the Axis video encoder on the network, please see the video encoder's own installation guide.

Installation steps

Follow these steps to install the AXIS Q7900 on your local network (LAN):

1. Check the package contents against the list below.
2. Hardware overview. See page page 4.
3. Install the hardware. See page 5.

Important!

This product must be used in compliance with local laws and regulations.







ENGLISH

1 Package contents

Please contact your dealer if anything is missing or damaged.

Item	Models/variants/notes
Video encoder rack	AXIS Q7900
2 cover plates	<ul style="list-style-type: none"> • 1 1-port front panel cover • 6 2-port front panel covers
1 AC power cord	<ul style="list-style-type: none"> • Europe • UK • US, Canada, Japan • Australia • Switzerland • Denmark • South korea
Terminal connectors	<ul style="list-style-type: none"> • 28 14-pin terminal connectors • 14 2-pin terminal connectors
Printed materials	<ul style="list-style-type: none"> • AXIS Q7900 Installation Guide (this document) • Axis Warranty Document
Mounting kit	See separate inventory below

Power cord plug variants

Country	Europe	UK	US, Canada, Japan	Australia	Switzerland	Denmark	South Korea
Power cord plug							

2 Hardware overview

AXIS Q7900 Rack (Rear View)

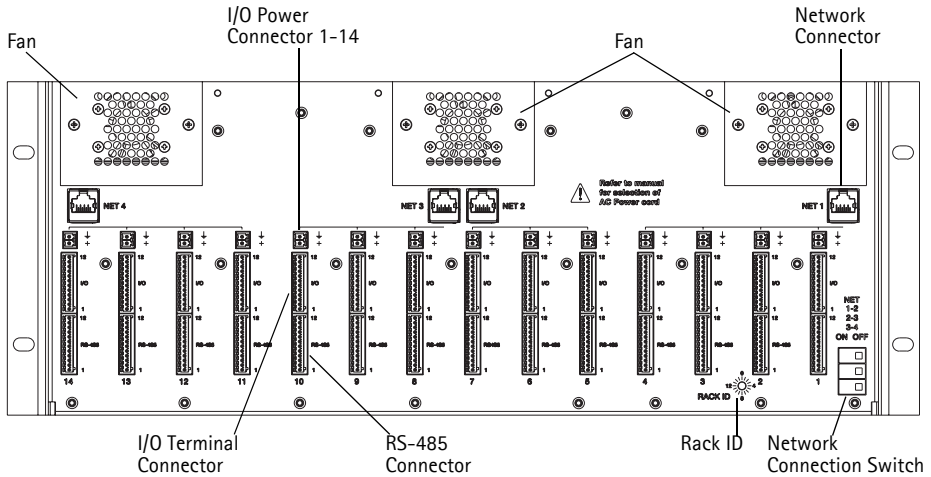

AXIS Q7900 Rack (FrontView)

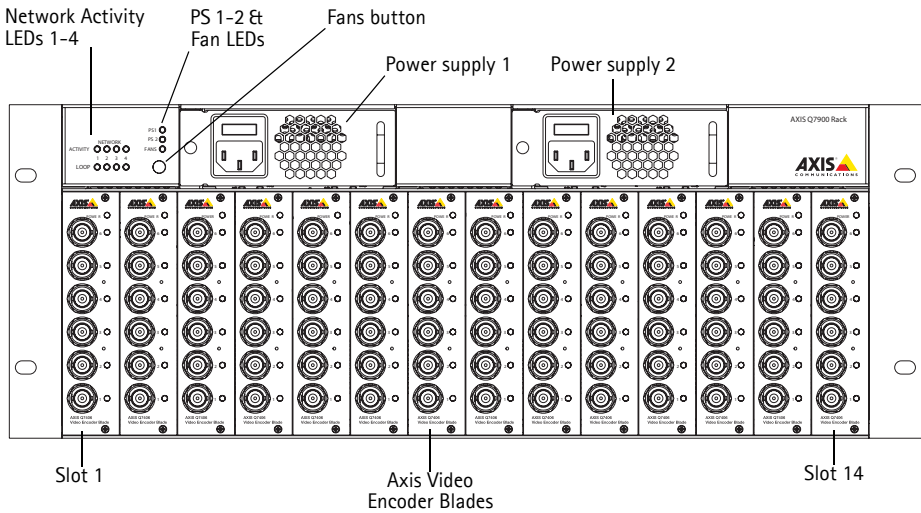

ENGLISH

3 Install the hardware

General placement requirements

The location of the AXIS Q7900 must meet the following requirements:

- Ambient temperature: 0° to +45°C (32° to 113°F)
- Relative humidity: 20-80%
- Power source within 1.8 meters
- There must be a minimum of 5cm free space on the top, bottom, front and rear of the AXIS Q7900 to ensure adequate ventilation
- No excessive dust

Placement requirements for installation in a 19" equipment rack

When mounting the AXIS Q7900 in an equipment rack, never stack other units directly on top - the mounting brackets are not designed to support more than 1 unit.

- Pozidriv screwdriver #1
- Pozidriv screwdriver #3
- The AXIS Q7900 must be grounded to the same ground as the equipment rack.
- The equipment rack must be braced and bolted to the floor.

Connect power

The AXIS Q7900 has two On/Off switches. Please ensure that the correct AC power cord for your country is used.

Note also the following requirements and restrictions:

- To prevent the risk of electrical shock when in contact with the unit casing, only earthed/grounded power cords should be used to power the AXIS Q7900.
- Protection against overcurrents, short circuits and earth faults should be provided in the building installation.
- The AXIS Q7900 is intended for indoor use only, and only for TN and IT power systems.
- If a foreign object is accidentally dropped into the Video encoder Rack, always disconnect power before attempting to remove the object.
- To turn off power to the AXIS Q7900, both power supplies must be turned off.

Axis video encoder blades

S/N – (serial number) is identical to the unit's MAC/Ethernet address,
e.g. 00408C1A2B3C = 00-40-8C-1A-2B-3C.

P/N – is the product's model number.

Bus Connector – This is the physical interface to the I/O terminal connector on the rack.

DIP Switches – Each video input has a corresponding line termination DIP switch. Axis video encoder blades are supplied with the line termination enabled for each input; i.e. with the DIP switches set to ON (down position).

To connect the video encoder in parallel with other equipment, disable the input termination by setting the corresponding DIP switch to OFF (up position). Failure to do so may affect the image quality negatively.

For detailed hardware information about a particular Axis video encoder blade, please refer to its installation guide.

Mounting Axis video encoder blades

The AXIS Q7900 can accommodate 14 Axis video encoder blades. The slots for these are numbered 1-14 from left to right. See *Hardware overview*, on page 4.

There are four slot groups in the AXIS Q7900: 1-4, 5-7, 8-10 and 11-14. If a slot group is to be used, the first slot in the slot group must be occupied. So if the first slot group is to be used, there must be a blade in slot 1. If slots 5 through 7 are to be used, there must be blade in slot 5 etc..

For example, if you have three blades and want to put them into the first group of slots 1-4, one of the three blades must occupy slot 1. The other two blades could occupy either slot 2, 3 or 4. Or if three slot groups were to be used, the first blade could occupy slot 1 or 5, the second blade could occupy slot 5 or 8, and the third blade could occupy slot 8 or 11.

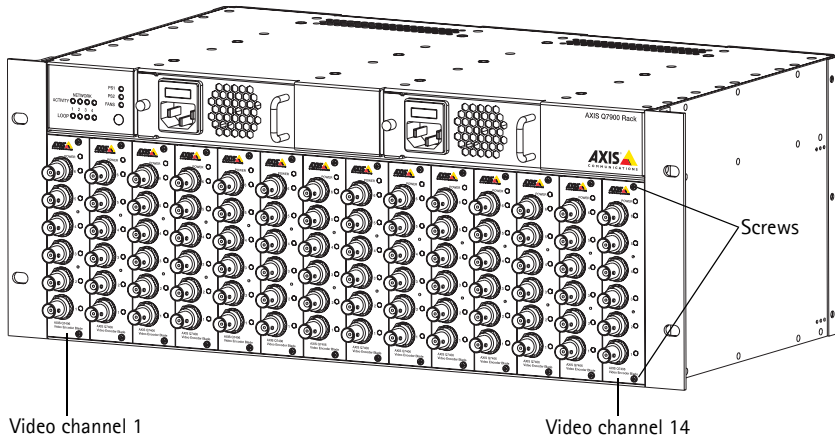

Follow these steps to mount an Axis video encoder blade in the AXIS Q7900:

1. If there is a front panel cover, remove it from the slot in to which the video encoder will be mounted. This is done by unfastening the screw at the top and bottom of the cover.
2. Slide the video encoder into place, using the guides as an aid. Make sure that video channel (1) is at the bottom of the blade when it is inserted into the AXIS Q7900.
3. Fix the video encoder in place, using the screws from the front panel cover.

Note: Front panel covers should be used on all empty slots.

Unit connectors

Rear connectors

Network Connector – Axis video encoder blades are designed for 10/100/1000 Mbps networks and connect via the standard RJ-45 connector.

Network Connector Switch – The Network Connector Switch controls which blades are connected to a particular network connector. The following table shows how the blades are connected based on how the switches are set. These settings are only made during power up.

NET 1-2 switch	NET 2-3 switch	NET 3-4 switch	NET1 connector	NET2 connector	NET3 connector	NET4 connector
Off	Off	Off	Blade 1-4	Blade 5-7	Blade 8-10	Blade 11-14
On	Off	Off	Blade 1-7	Do not connect	Blade 8-10	Blade 11-14
Off	On	Off	Blade 1-4	Blade 5-10	Do not connect	Blade 11-14
On	On	Off	Blade 1-10	Do not connect	Do not connect	Blade 11-14
Off	Off	On	Blade 1-4	Blade 5-7	Blade 8-14	Do not connect
On	Off	On	Blade 1-7	Do not connect	Blade 8-14	Do not connect
Off	On	On	Blade 1-4	Blade 5-14	Do not connect	Do not connect
On	On	On	Blade 1-14	Do not connect	Do not connect	Do not connect

Rack ID – Sets a rack ID for all blades in the rack. Possible ID 0 to 15. The Blade ID, will correspond to the slot number.

RS-485 Connector – Usually used for connecting Pan Tilt Zoom devices. See page 9 below for pin assignment information.

I/O Power Connector(s) – 12VDC 100mA out. This connector could be used to supply power to external units connected to the I/O port.

I/O Terminal Connector(s) – Provides the physical interface for up to 12 I/Os. See page 10 below for pin assignment information.

Front connectors

Network Activity LEDs 1-4 – 10/100 yellow flashes with activity, 1000M green, flashes with activity.

PS1 LED – This will indicate a RED light when there is an error in Power supply 1. Please shut down PS1 and replace with a new power supply. It also indicates if PS1 is disconnected

PS2 LED – This will indicate a RED light when there is an error in Power supply 2. Please shut down PS2 and replace with a new power supply. It also indicates if PS2 is disconnected

FAN LED – This will indicate if one or more FANS need to be replaced with new ones. Please replace the fans and reset the fans warning.

FANS button – This will reset the fan warning.

Power supply 1 and 2 – Replaceable and redundant power supply. 100–240VAC input.

Pin assignments

Pin assignments for the RS-485 connector of the AXIS Q7900 Rack

Pin	AXIS Q7406	AXIS 243Q	AXIS 241Q/S, AXIS 240Q
12	Channel 6, RS485B	NC	NC
11	Channel 6, RS485A	NC	NC
10	Channel 5, RS485B	NC	NC
9	Channel 5, RS485A	NC	NC
8	Channel 4, RS485B	NC	NC
7	Channel 4, RS485A	NC	NC
6	Channel 3, RS485B	NC	NC
5	Channel 3, RS485A	NC	NC
4	Channel 2, RS485B	NC	NC
3	Channel 2, RS485A	NC	NC
2	Channel 1, RS485B	Channel 1, RS485B	RS485B
1	Channel 1, RS485A	Channel 1, RS485A	RS485A

Note: For RS-485 unit connector information for video encoders, refer to their respective Installation Guide for I/O connector information.

Pin assignments for the I/O Connector of the AXIS Q7900 Rack

Pin	AXIS Q7406	AXIS 243Q	AXIS 241Q/S, AXIS 240Q
12	Channel 6, Configurable I/O 2	NC	NC
11	Channel 5, Configurable I/O 2	NC	NC
10	Channel 4, Configurable I/O 2	NC	NC
9	Channel 3, Configurable I/O 2	NC	NC
8	Channel 2, Configurable I/O 2	Channel 4, Output1	Output4
7	Channel 1, Configurable I/O 2	Channel 3, Output1	Output3
6	Channel 6, Configurable I/O 1	Channel 2, Output1	Output2
5	Channel 5, Configurable I/O 1	Channel 1, Output1	Output1
4	Channel 4, Configurable I/O 1	Channel 4, Input 1	Input4
3	Channel 3, Configurable I/O 1	Channel 3, Input 1	Input3
2	Channel 2, Configurable I/O 1	Channel 2, Input 1	Input2
1	Channel 1, Configurable I/O 1	Channel 1, Input 1	Input1

Note: For I/O unit connector information for video encoders, refer to their respective Installation Guide for I/O connector information.

Replacing a power supply

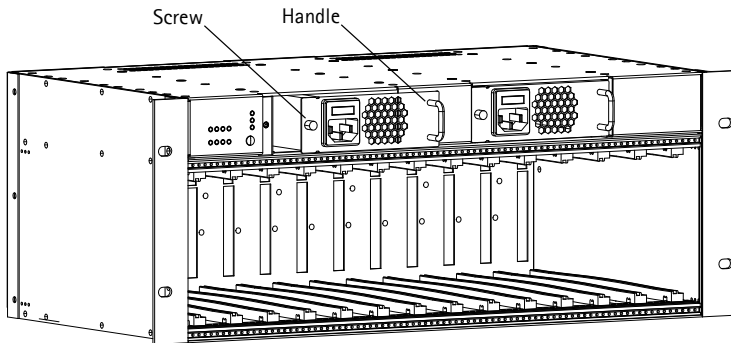

1. Turn off the power supply that needs to be replaced.
2. Loosen the screw located on the left side of the power supply and remove the power supply using the handle.
3. Insert a new power supply and retighten the screw.
4. Turn on the new power supply to begin using it.

Replacing a fan

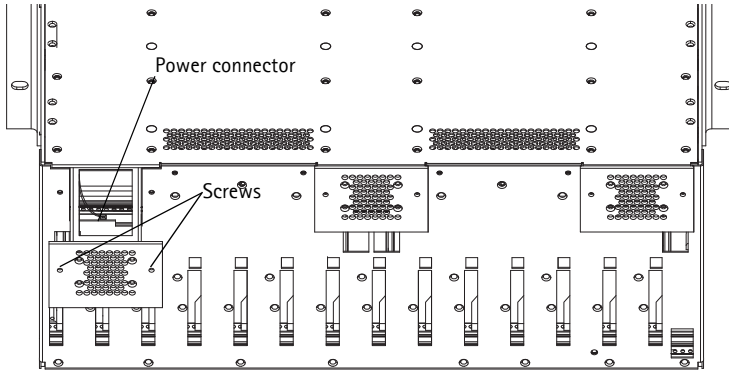

Follow these steps to replace a fan.

1. Loosen and remove the screws located on each side of the fan that needs to be replaced.
2. Gently pull out the fan far enough to disconnect it from the power connector.
3. Disconnect the fan and remove it completely.
4. Insert a new fan and reconnect it to the power connector.
5. Replace and retighten the screws.

Note: If one fan needs to be replaced, it is best to replace all three fans as soon as possible for optimum performance.

The following requirements apply for installation in Norway:

- the building installation shall provide a means for connection to protective earth; and
- the equipment is to be connected to that means; and

a SERVICE PERSON shall check whether or not the socket-outlet from which the equipment is to be powered provides a connection to the building protective earth. If not, the SERVICE PERSON shall arrange for the installation of a PROTECTIVE EARTHING CONDUCTOR from the separate protective earthing terminal to the protective earth wire in the building.

