



Extreme CCTV®
SURVEILLANCE SYSTEMS

INSTALLATION INSTRUCTIONS

EX82MECC2
IDN Camera



www.ExtremeCCTV.com

Toll free: 1-888-409-2288
MAN-82MECC2-02



IMPORTANT

For best results, please read this Instruction Booklet
prior to installing the **EX82MECC2 Camera**



WARNING !

CSA Certified / UL Listed CLASS 2 power adaptors must be
used in order to comply with electrical safety standards.

Only qualified personnel shall install any **EXTREME CCTV®**
surveillance camera. **EXTREME CCTV®** will not be
responsible for injuries or damages resulting from the
improper installation
or use of any equipment sold by **EXTREME CCTV®**,
their agents, distributors or dealers.

INDEX – EX82MECC2 Camera

	PAGE
Description	3
Unpacking	3
Parts List	4
Items Required for Installation	4
Initial Preparations	4
Guidelines	4
Mechanical Specifications – Camera	5

SECTION

1. Camera - Internal Modules Locations and Access	6
2. Power Input / Video Output Connections	7
3. Mounting – Camera Housing	10
4. Camera Lens Adjustment	12
5. LED Array – Power Adjustments	15
6. Camera Re-Assembly	16
7. Troubleshooting Guide – Camera	17
8. Troubleshooting Guide – LEDs	19
9. General Specifications	20
10. Template, Mounting Bracket	22

DESCRIPTION

The **EX82MECC2** surveillance unit consists of two cameras (color and monochrome), an IR LED Array, and two external connections for Power Input and MECC Accessories.

The two cameras give optimum color performance during daylight conditions and LXR-infrared illuminated performance in the pitch black of night.

Both cameras have “Vari Focal” lenses and are seamlessly switched by a photocell when light conditions change from day to night, ensuring “No Focus Shift”.

An all-weather housing with tough polycarbonate windows contains all the electronics. Low power consumption LED illuminators and solid-state CCD technology make this camera very reliable and efficient.

The **EX82MECC2** can operate at *12V dc* or *24V ac*, and a range in between, with protection from voltage surges, transient spikes, and reverse voltage.

For additional information, contact Extreme CCTV® -

- sales@ExtremeCCTV.com
- Tel: 1-888-409-2288 (Toll free NA)
- Web: www.ExtremeCCTV.com

See the Light. Get the Picture.™

UNPACKING

Care should be taken when unpacking the shipped unit. Check the parts list and confirm all items have been located. Inspect the equipment thoroughly to ensure nothing was damaged in transit.

If a problem is noted, contact Extreme CCTV®:

- quality@ExtremeCCTV.com
- Tel: 1-604-420-7711 or see the rear of this booklet for contact information.

PARTS LIST (items supplied with unit)

- **EX82MECC2** Camera Unit
- Installation Instructions booklet
- Wall mounting bracket
- MECC accessory and power cable

ITEMS REQUIRED FOR INSTALLATION (not supplied)

- Mounting hardware
- Mounting tools

INITIAL PREPARATIONS

- Determine the operating voltage at the installation site. The camera's Voltage Regulator Board accepts both 12 - 30V dc or 17 - 28V ac input without change to internal connections.
See Section 2, Input Power Connections.
- Determine the optimum location for the camera.
See Section 3, Mounting-Camera Housing.
- All cameras have been tested prior to shipment. It is advisable to re-check the camera's operation if any wiring changes were performed.
Refer to the Troubleshooting Guide, Sections 7 & 8, if any problems are noted.

GUIDELINES

The installation of the **EX82MECC2** camera is explained in Sections 1 to 6. It is important that these steps are followed in sequence:

1. Camera Housing – Internal Modules and Access
2. Power Input / Video Output Connections
3. Mounting - Camera Housing
4. Camera Lens Adjustments
5. LED Array - Power Adjustments
6. Camera Re-Assembly

MECHANICAL SPECIFICATIONS – EX82MECC2
(See Section 9 - General Specifications, for more information)

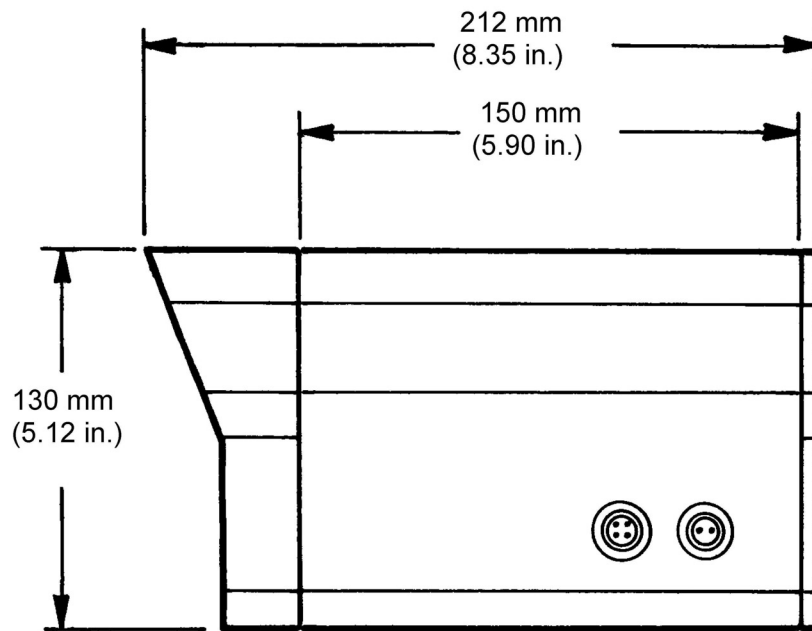

Side View

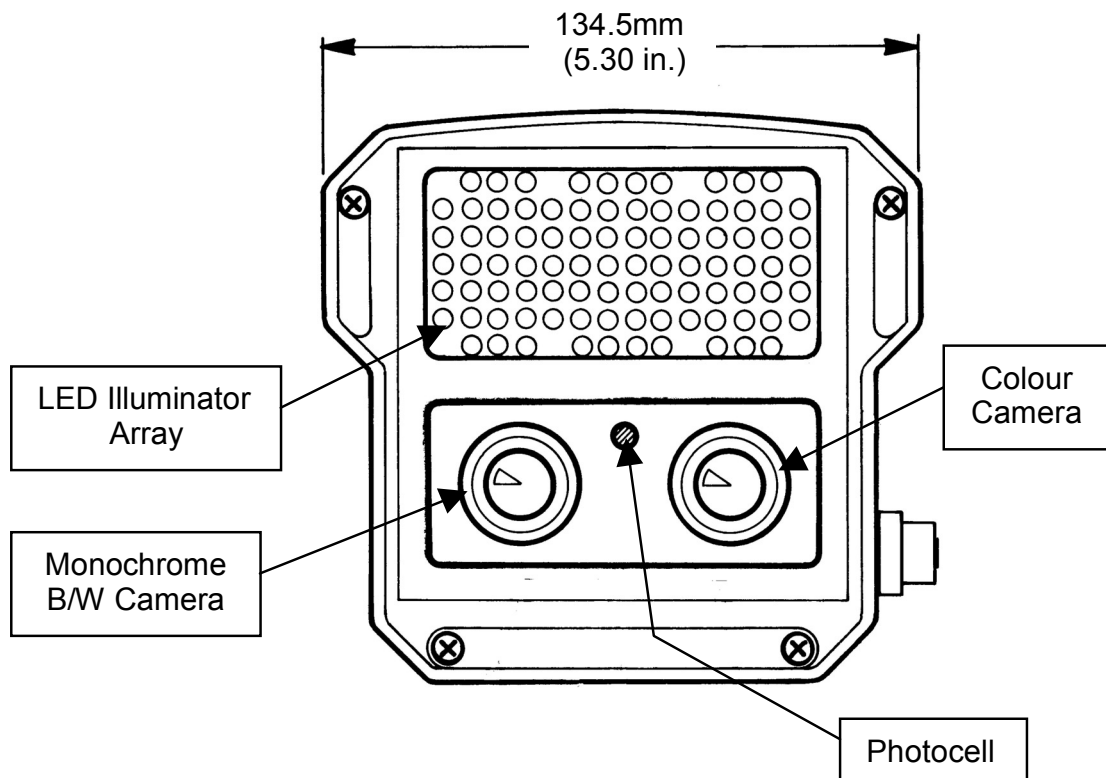

Front View

1. CAMERA HOUSING – INTERNAL MODULE LOCATIONS and ACCESS.

Step 1.1 - Loosen the captive screws that secure the faceplate and the rear cover to the camera housing.

Step 1.2 - Carefully separate the faceplate and rear cover from the camera housing, ensuring the gaskets stay in place and the photocell is not dislodged or unplugged.

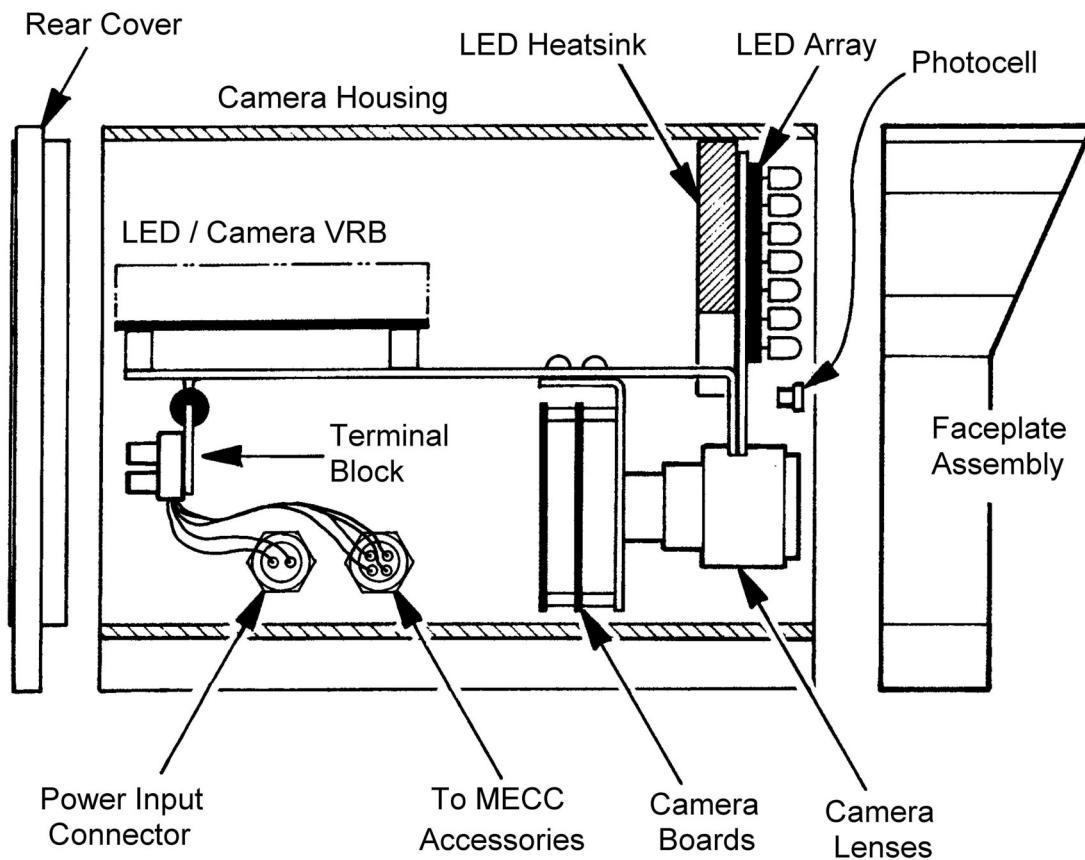

FIGURE 1 – 1
Module Location Diagram

2. POWER INPUT / VIDEO OUTPUT CONNECTIONS

The **EX82MECC2** is pre-connected for 24V ac operation. Individually isolated power source for each unit must be used at 24VAC when connecting multiple cameras to prevent ground loops.

The Camera/LED VRB does not require wiring changes. Note: The power/video cable is connected to the MECC side connectors. Only the side connectors or power/video cable should be used at one time.

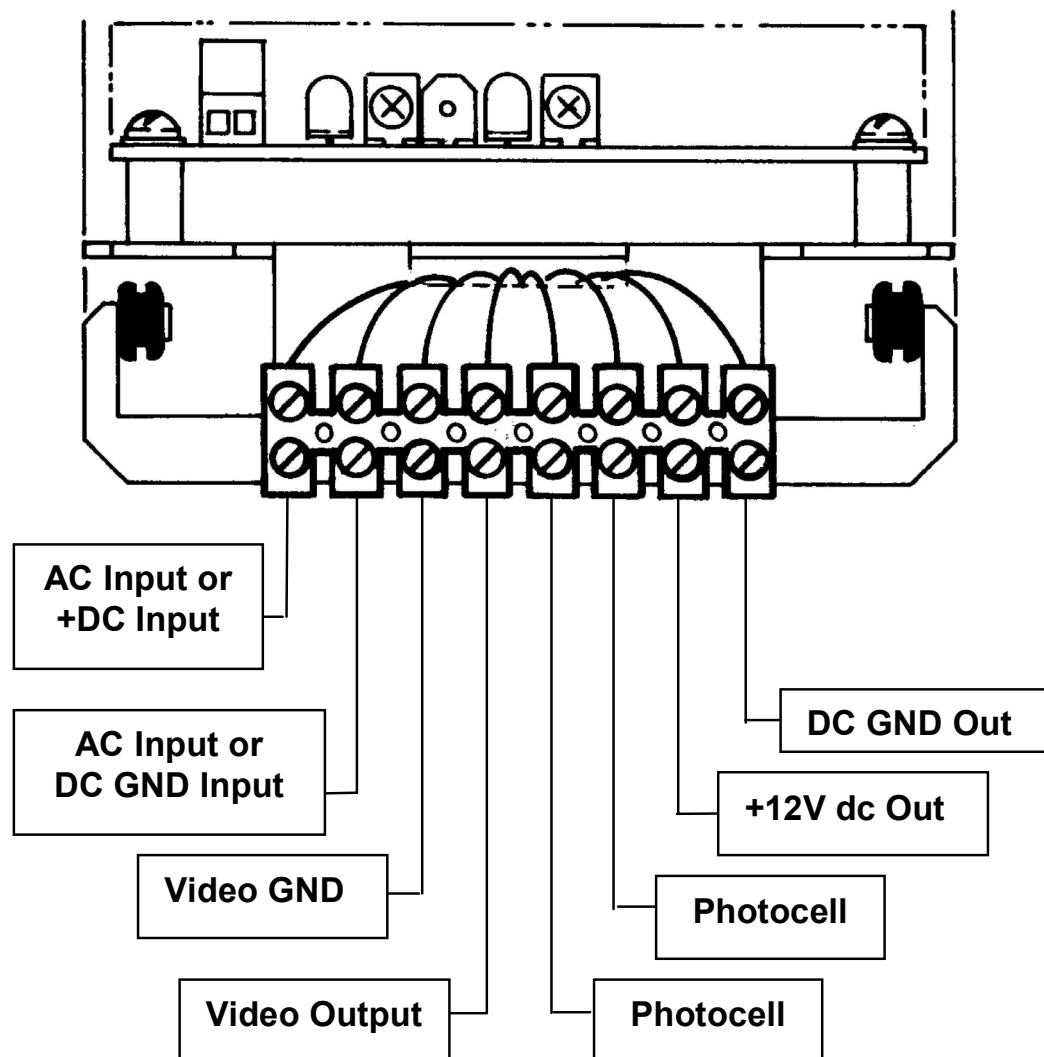

FIGURE 2 – 1
Terminal Block - Input / Output Wiring

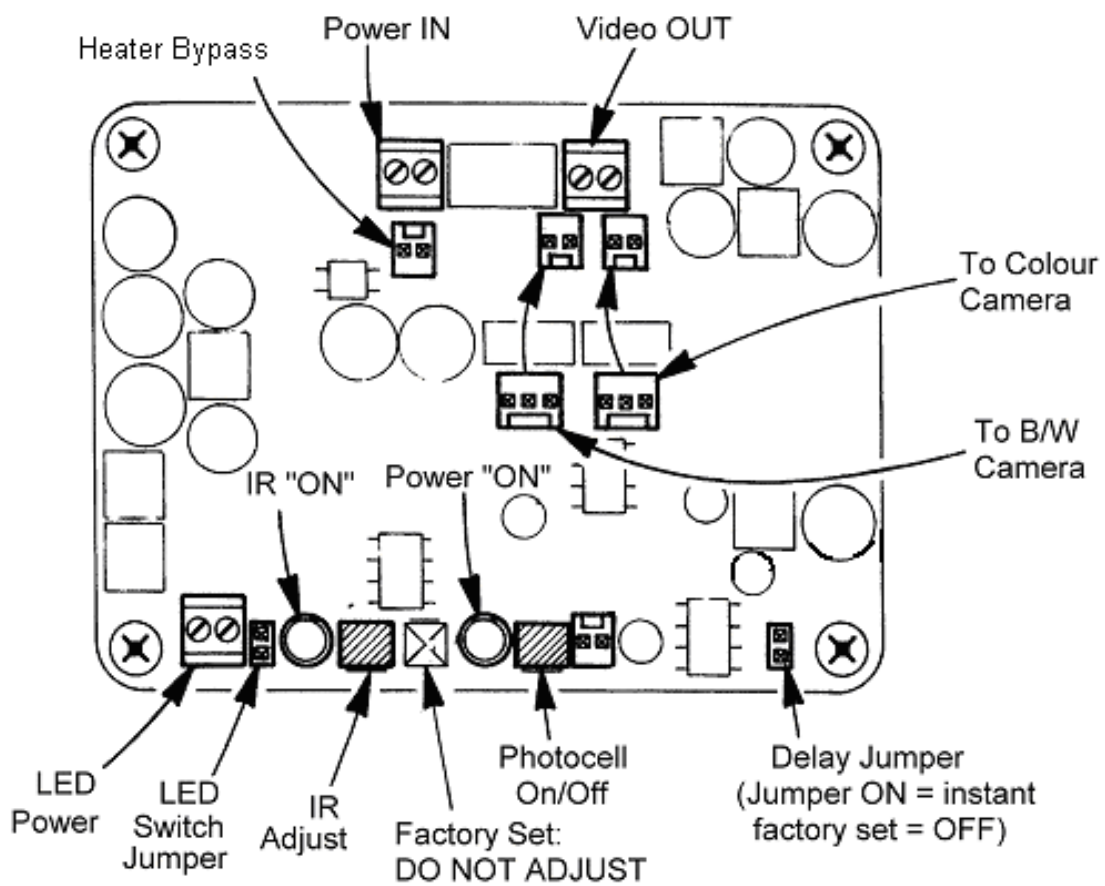

FIGURE 2 - 2
Adjustable Components, Camera / LED VRB

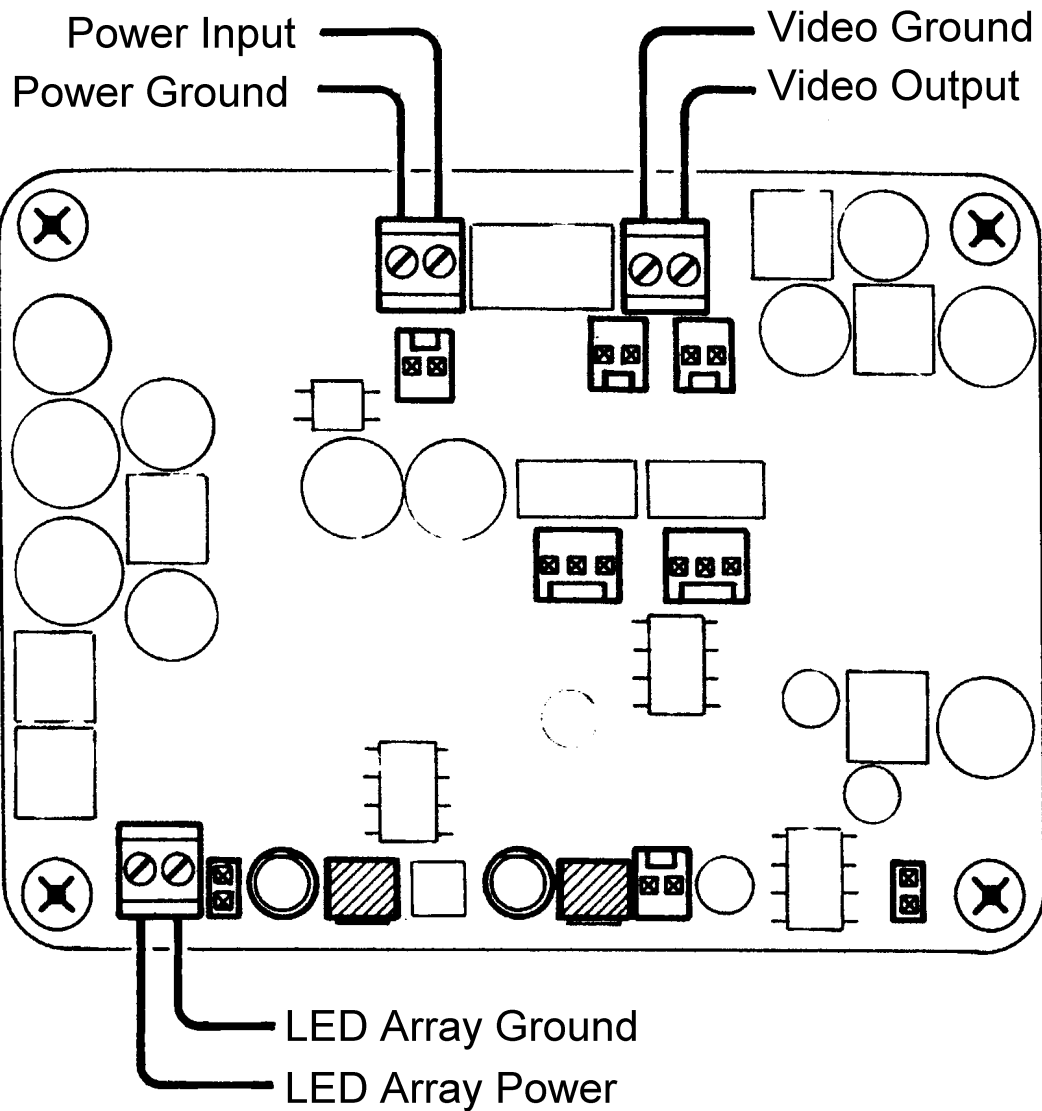

FIGURE 2 - 3
Input and Output Wiring Connections, Camera / LED VRB

3. MOUNTING – CAMERA HOUSING



*Caution: Install with the appropriate screws or drywall anchors to suit the mounting surface. Select a suitable location that is protected from accidental damage, tampering and environmental conditions, which could exceed the camera's specifications.
See page 20.*



Caution: Ensure the selected location is protected from falling objects, accidental contact with moving objects, and unintentional interference from personnel. Follow all applicable building codes.



 **The following installation guidelines must be followed:**

- Locate the camera such that it cannot be easily interfered with, either intentionally or accidentally.
- Select a mounting surface capable of supporting the combined weight of the camera and mounting hardware under all expected conditions of vibration and temperature.
- Secure all cabling.

Installations on drywall must use four #12 screws and #12 drywall plugs or a superior mounting method.

3. MOUNTING – CAMERA HOUSING (continued)

Attach the front faceplate and the rear cover, ensuring that the gaskets are properly seated, no wires are crimped, and the photocell is in its proper viewing location.

Bolt the camera's mounting bracket to the selected mounting surface as per guidelines on page 10.

Connect the power source and the MECC accessory box to the two connectors located on the side of the camera housing.

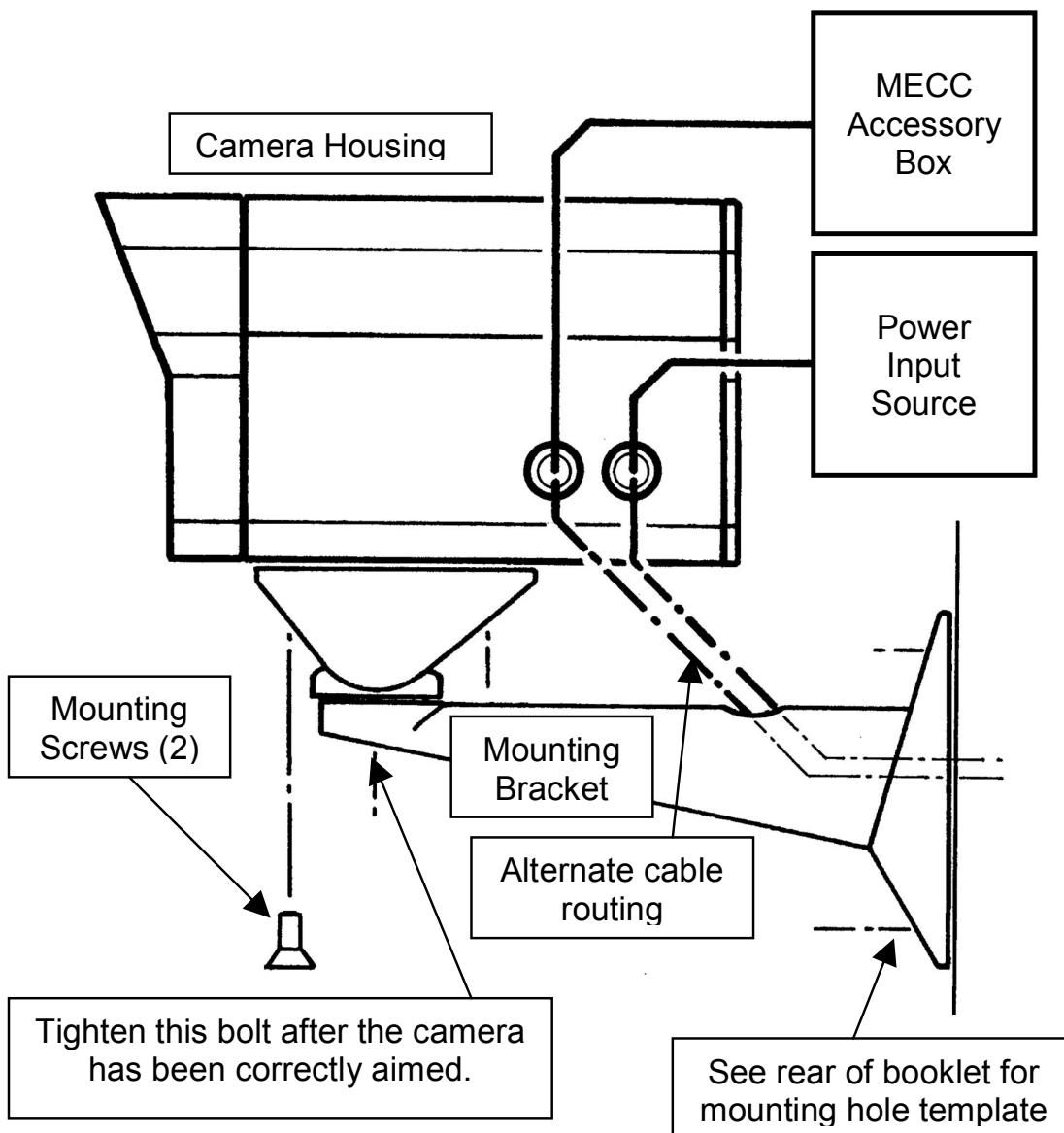

FIGURE 3 – 1
Mounting Details – Camera Housing & External Modules

4. CAMERA LENS ADJUSTMENTS

For optimum picture quality, the camera lens should be as close as possible to the inside face of the viewing window, without touching.

Remove the faceplate and the foam lens protector. Make sure the photocell is not dislodged. Loosen the three screws securing the LED/Camera lens assembly bracket to the LED heatsink. Slide out the assembly bracket to its "forward stop" position. See **Figure 4-1** below.

The inside clearance of the lens can be achieved by:

- (a) loosening the screws which secure the Camera / Lens mounting bracket,
- (b) sliding the bracket to its new location, and
- (c) re-tightening the screws.

See **Figure 4-2** on page 13.

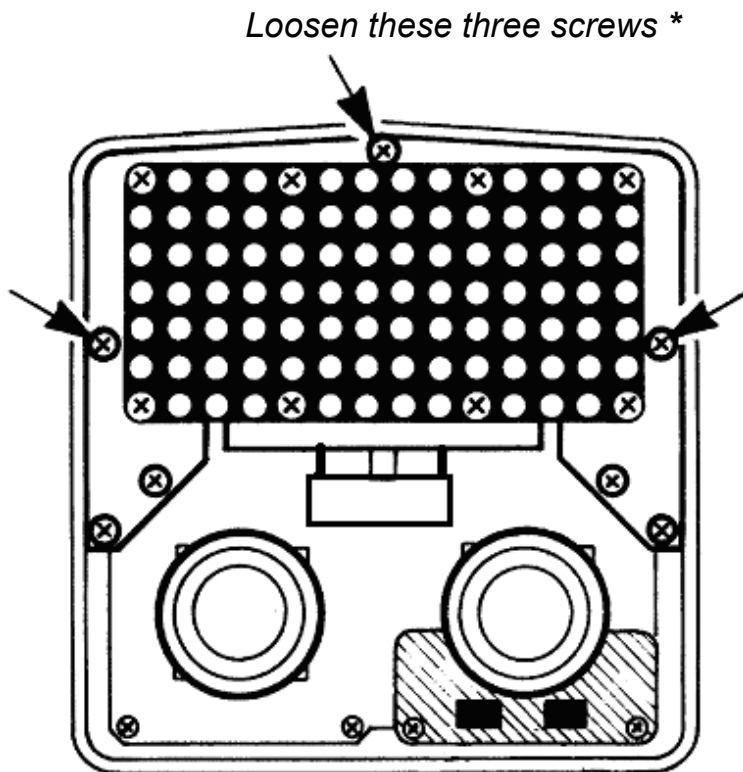

* These screws are captive and should be loosened to the point where the bracket assembly can be moved forward.

FIGURE 4 – 1
LED/Camera Lens Bracket Removal

Loosen these screws to adjust the
Camera / Lens Mounting Bracket

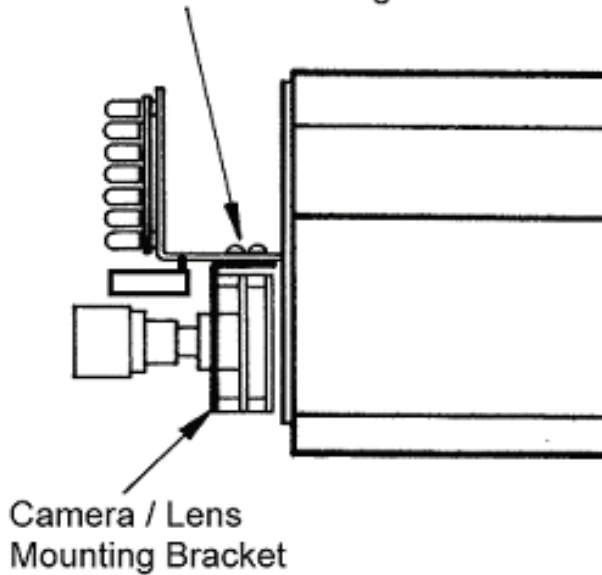

FIGURE 4 – 2
Camera / Lens Mounting Bracket Adjustment

4.1 Vari Focal and “Auto-Iris” Control Adjustments

Note: Completely cover photocell for B/W mode and IR “On”.

- Step 4.1.1 - Loosen the lens setscrews for focus/zoom adjustments. See **Figure 4-3** on page 14.
- Step 4.1.2 - The setscrew marked **N** $\longleftrightarrow \infty$ is used for image focus.
- Step 4.1.3 - The setscrew marked **T** \longleftrightarrow **W** is used for telephoto or wide-angle settings.
- Step 4.1.4 - Re-tighten the setscrews after focus adjustments have been completed.
- Step 4.1.5 - Locate the “Auto-Iris” adjustment controls (if so equipped) as shown in **Figure 4-4** on page 14 and as per Tables **A** and **B** on page 15.

Loosen this set screw
for Focus Adjustment.

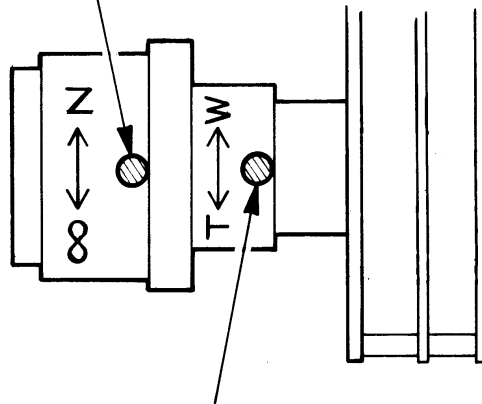

Loosen this set screw for
Telephoto or Wide Angle
Adjustment.

FIGURE 4 – 3
Lens Focus Adjustment

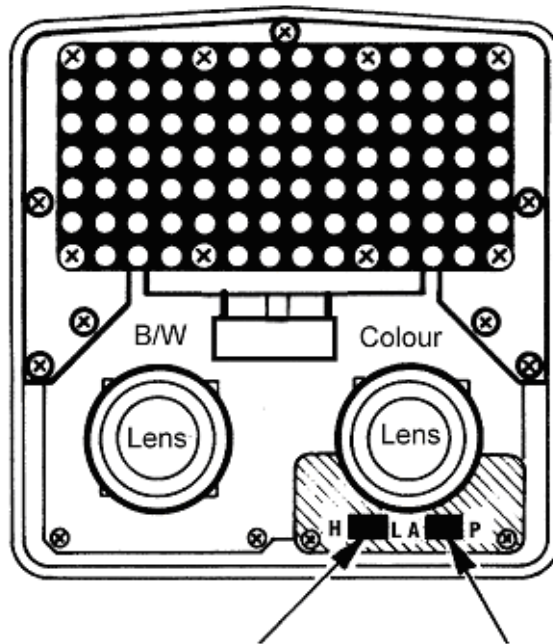

Level Control

ALC Control

FIGURE 4 – 4
Adjustments, “Level” and “ALC” Controls

Table A – ALC Adjustment

ALC Mode Select	ALC Adjustment
Metering to the “peak” light intensity of the image	Turn towards “P”
“Average” metering over the image	Turn towards “A”

Table B – Brightness Level Adjustment

Brightness	LEVEL Adjustment
For a brighter picture	Turn towards “H”
For a darker picture	Turn towards “L”

Step 4.1.6 - After adjustments are complete, re-install the LED/Camera lens assembly bracket back onto the LED heatsink.

5. LED ARRAY - POWER ADJUSTMENTS

Remove the rear cover for access to the VRB.
The **EX82MECC2** needs to be powered-up while making the LED power adjustments.

Cover or adjust the photocell to turn the LEDs “ON” (850nm LEDs will have a slight red glow while 940nm LEDs are covert).

Adjust the LED power if they are too bright or too dim.
Refer to **Figure 5-1** on page 16.

Note: LED power is factory-set to “High”.

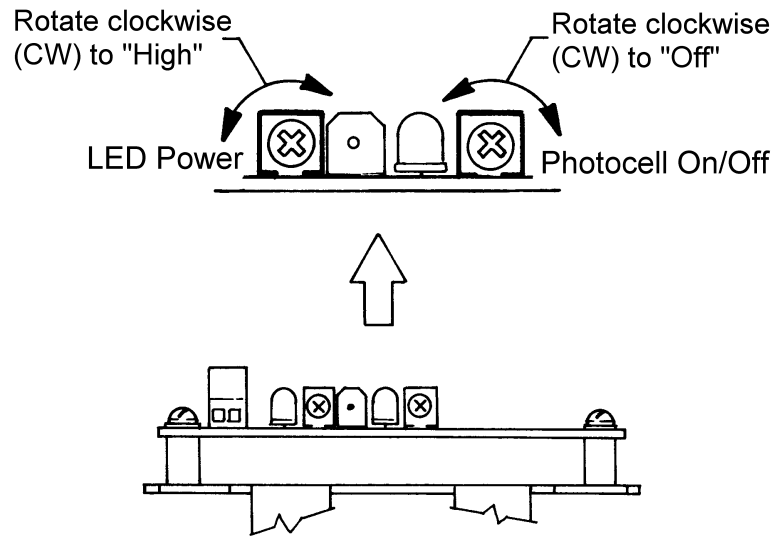

For LED power adjustment, rotate clockwise (CW) for “High” and counter-clockwise (CCW) for “Low”.
 For photocell “On/Off” light-level adjustment, rotate clockwise (CW) for “Off” and counter-clockwise (CCW) for “On”.
Note: Off is IR “Off” or Colour Mode.

FIGURE 5 - 1
LED Power and Photocell On/Off Adjustments

6. CAMERA RE-ASSEMBLY

Make sure all wires are properly connected and tightened into the terminal blocks, all holes are sealed against moisture penetration, and all mounting screws are tight.

Step 6.1 - Slide the rectangular foam pad over the camera lens. Make sure the pad is snug and as close to the faceplate viewing window as possible and the photocell is secure with an unobstructed view.

Step 6.2 - Attach the faceplate and the rear cover to the camera housing. Tighten on the faceplate.

Step 6.3 - Tighten the camera’s adjustable mounting bracket after the desired viewing angle has been determined.

Step 6.4 - Power-up the camera and check its operation.

7. TROUBLESHOOTING GUIDE - CAMERA

<i>PROBLEM</i>	<i>POSSIBLE CAUSE</i>	<i>LIKELY SOLUTION</i>
No Video	<p>1. <u>Power Supply</u>:</p> <p>-Connections....</p> <p>-Voltage Range...</p> <p>2. <u>Video Connections</u></p> <p>3. <u>IP connection</u></p>	<p>Check the input power connections at the terminal block, ensuring no wires are loose.</p> <p>The supply range is: <i>17 – 28V ac OR</i> <i>12 – 30V dc.</i> Measure the voltage at the terminal block.</p> <p>Determine if the wiring polarity at the “Video Connector” terminal block is correct. Check BNC connector.</p> <p>If still no video, connect the camera directly to the monitor. Check the video signal. If okay, the problem is with the interconnections.</p> <p>Check network connection.</p> <p>Check software installation.</p>

7. TROUBLESHOOTING GUIDE – CAMERA (cont'd.)

<i>PROBLEM</i>	<i>POSSIBLE CAUSE</i>	<i>LIKELY SOLUTION</i>
Poor Picture Quality		
Dim/bright Image	Iris closed/open	Adjust iris level on lens.
Snowy Image	Poor Video Signal	Ensure the video cable is correctly matched and terminated with 75 ohms at each end. Make sure the video cables are compatible.
	Noisy Power Supply	Check all power connections. Relocate or replace the power supply.
Horizontal Scan Lines, Rolling Up or Down	Ground Looping on Video Cable	Check the coax cable shield is not grounded, e.g.- at the couplings. An electrically isolated circuit board or isolation transformer may be required.
Negative, Scrambled, or Faded Image	Low Voltage	Check voltage at input power cable. Must be >12V dc or >17V ac. Check video leads for reversed connections.

8. TROUBLESHOOTING GUIDE - LEDs

<i>PROBLEM</i>	<i>CAUSE</i>	<i>SOLUTION</i>
Don't know if the LEDs are "ON"	850nm LEDs will emit a faint red glow when "ON". 940nm LEDs are covert.	<ol style="list-style-type: none"> 1. Check the IR "ON" LED on the VRB module at the rear of the camera. 2. Aim the LEDs directly at an IR sensitive camera. 3. Wait for the LEDs to warm up (> 2 minutes).
The LEDs are not "ON"	Ambient light or an external light source is triggering the photocell.	<ol style="list-style-type: none"> 1. Cover the photocell for activation of power to the LEDs (up to 30 seconds delay). 2. On the VRB, adjust the photocell's variable resistor towards the "ON" position. 3. On the VRB, adjust the power to the LEDs.
The LEDs are not "OFF" when sufficient ambient light is present	The photocell is blocked or the variable resistor is in the "OFF" position.	<ol style="list-style-type: none"> 1. Ensure the path of the photocell's viewing direction is not blocked by any object. 2. On the VRB, adjust the photocell's variable resistor towards the "OFF" position.

9. GENERAL SPECIFICATIONS

Power Consumption 22W Max.

Input Voltage 17 – 28V ac

..... 12 – 30V dc

Enclosure..... Aluminum casting and extrusion

Viewing Window ¼” Lexan

Dimensions..... 130mm **H** (5.12”)

134.5mm **W** (5.30”)

212mm **L** (8.35”)

Weight 2.2kg (4.9 lbs.)

Subject to change without notice.



Extreme CCTV®

SURVEILLANCE SYSTEMS

Canada

3021 Underhill Ave.,
Burnaby, BC V5A 3C2

USA

3873 - C Airport Way,
PO Box 9754,
Bellingham, WA 98227

tel

1-888-409-2288 (toll free)
1-604-420-7711

fax

1-604-420-3300

e-mail

tech@ExtremeCCTV.com

Web

www.ExtremeCCTV.com

Europe

Colbourne Cres.
Cramlington,
Northumberland
United Kingdom, NE23 1WB

tel

+44(0)1670.730.187

fax

+44(0)1670.730.188

Dealer:

10. TEMPLATE – MOUNTING BRACKET



Cut vertically

TOP EDGE OF BRACKET

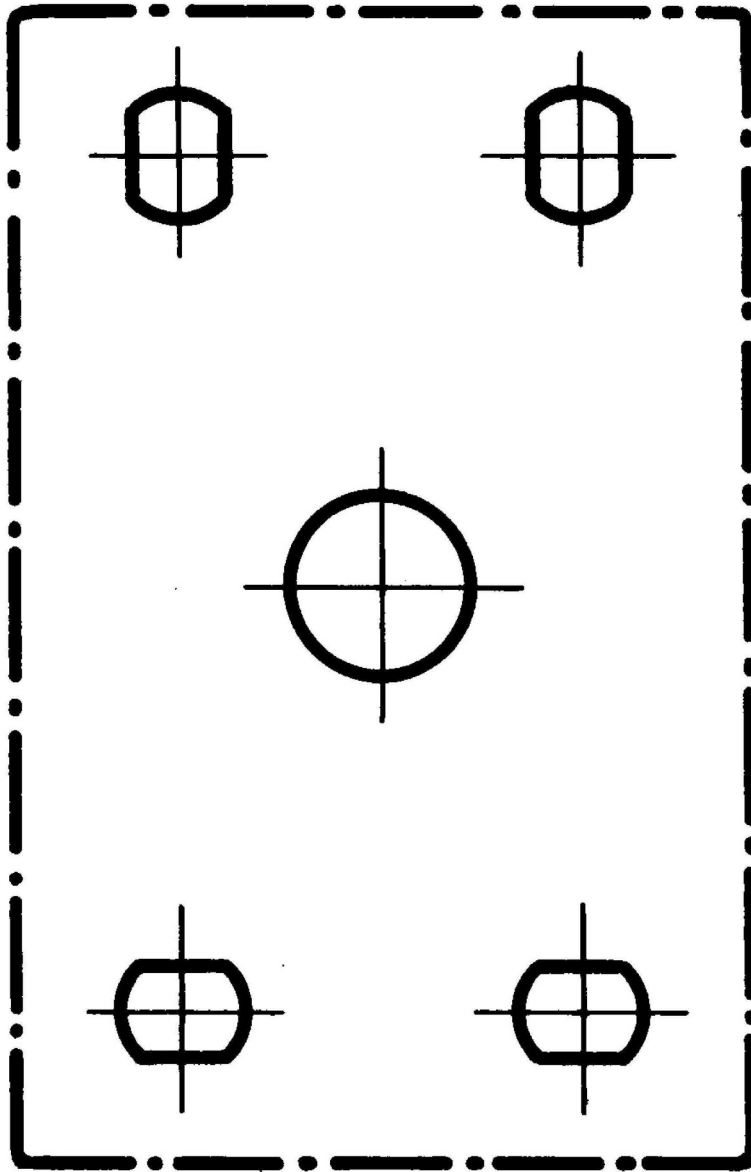

Cut vertically

