



Extreme CCTV®
SURVEILLANCE SYSTEMS

INSTALLATION INSTRUCTIONS

EX30/38 IDN Surveillance Camera



www.ExtremeCCTV.com

Toll free: 1-888-409-2288
MAN-30-38-00



IMPORTANT

For best results, please read this Instruction Booklet prior to installing the **EX30/38 IDN Camera**



WARNING !

CSA Certified / UL Listed CLASS 2 power adaptors must be used in order to comply with electrical safety standards.

Only qualified personnel shall install any **EXTREME CCTV®** surveillance camera. **EXTREME CCTV®** will not be responsible for injuries or damages resulting from the improper installation or use of any equipment sold by **EXTREME CCTV®**, their agents, distributors or dealers



Extreme CCTV®
SURVEILLANCE SYSTEMS

Made in Canada

12 Vdc, 22W(max)

24 Vac, 60 Hz, 22 W(max)



UL 2044

CSA C22.2 No. 1-M94

CSA C22.2 No. 0-M1991

NEC Class 2 Limited Power Circuit
See Installation Instructions For Proper Connections



EU Directives covered by this declaration:

72/9/EC Low Voltage Directives

89/336/EEC Electromagnetic Compatibility Directive

INDEX – EX30/38 IDN Camera

Description.....	1
Unpacking.....	2
Parts List.....	2
Items Required for Installation.....	2
Initial Preparations.....	3
Guidelines.....	3
Mechanical Specifications – Camera.....	4
1. Camera - Internal Modules Locations and Access.....	5
2. Input Power / Video Output Connections.....	6
3. Mounting – Camera Housing.....	8
4. Camera Lens Adjustment.....	10
5. LED Array – Power Adjustments.....	13
6. Window Defroster Unit.....	14
7. Camera Re-Assembly.....	15
8. Troubleshooting – Camera.....	16
9. Troubleshooting –LEDs.....	19
10. General Specifications.....	20

DESCRIPTION

The **EX30/38 IDN** Integrated Night and Day surveillance camera consists of an LXR camera and an infrared illuminator. This surveillance system gives optimum performance during daylight conditions and in the pitch black of night.

The camera has a “Vari Focal” lens, and is seamlessly switched by a photocell when light conditions change from day to night, ensuring no loss of image quality.

An all-weather housing with tough polycarbonate windows contains all the electronics. Low voltage operation, low power consumption, LED illuminators, thermostat controlled defroster and solid-state CCD technology make this camera very reliable and efficient.

A voltage regulator circuit allows for *DC* or *AC* operation, and also provides protection from voltage surges, transient spikes, and reverse voltage.

The **EX30/38** is available in several models designed to meet specific needs.

Contact Extreme CCTV® for information.

- sales@ExtremeCCTV.com
- Tel: 1-888-409-2288 (Toll free NA)
- Web: www.ExtremeCCTV.com

See the Light. Get the Picture.™

UNPACKING

Care should be taken when unpacking the shipped unit. Check the parts list and confirm all items have been located. Inspect the equipment thoroughly to ensure nothing was damaged in transit.

Contact Extreme CCTV® if a problem is noted.

- quality@ExtremeCCTV.com
- Tel: 1-604-420-7711 or see the rear of the booklet for contact numbers.

PARTS LIST (items supplied with unit)

- **EX30/38** camera assembly
- Installation Instructions booklet
- Cardboard box containing one adjustable wall - mounting bracket.

ITEMS REQUIRED FOR INSTALLATION (not supplied with units)

- Mounting hardware
- Mounting tools

INITIAL PREPARATIONS

- Determine the operating voltage at the installation site. The camera's Voltage Regulator Board accepts both 12-30V dc or 17-28V ac input without change to internal connections. See *Section 2, Input Power Connections*.
- Determine the optimum location for the camera. See *Section 3, Mounting-Camera Housing*.
- All cameras have been tested prior to shipment. After the wiring has been reconnected, it is advisable to check the camera's operation before installation.

GUIDELINES

The installation of the **EX30/38** camera is explained in Sections 1 to 7.

It is important that these steps are followed in sequence:

1. Camera Housing – Internal Access
2. Input Power / Video Output Connections
3. Mounting - Camera Housing
4. Camera Lens Adjustments
5. LED Array - Power Adjustments
6. Window Defroster Unit
7. Camera Re-Assembly

MECHANICAL SPECIFICATIONS – EX82DXL

(See Section 11 - General Specifications, for more information)

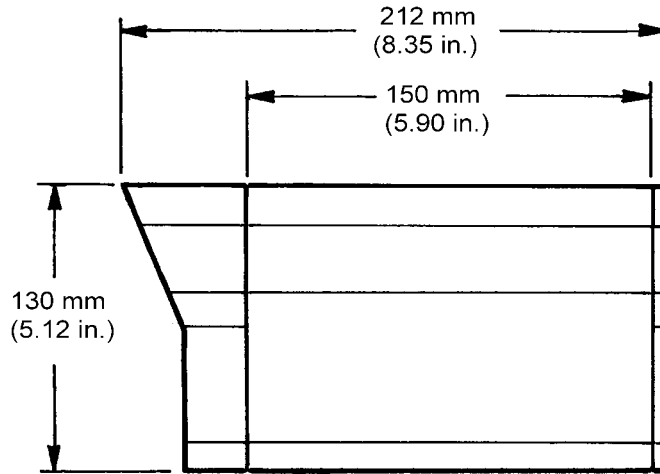

Side View

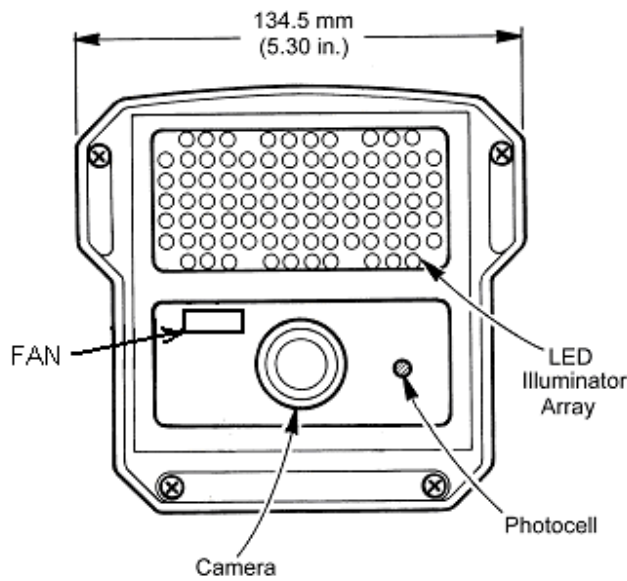

Front View

1. CAMERA HOUSING-- INTERNAL MODULE LOCATIONS and ACCESS

Step 1.1 - Loosen the captive screws which secure the faceplate and the rear cover to the camera housing.

Step 1.2 - Carefully separate the faceplate and rear cover from the camera housing. Make sure the gaskets stay in place and the photocell is not dislodged.

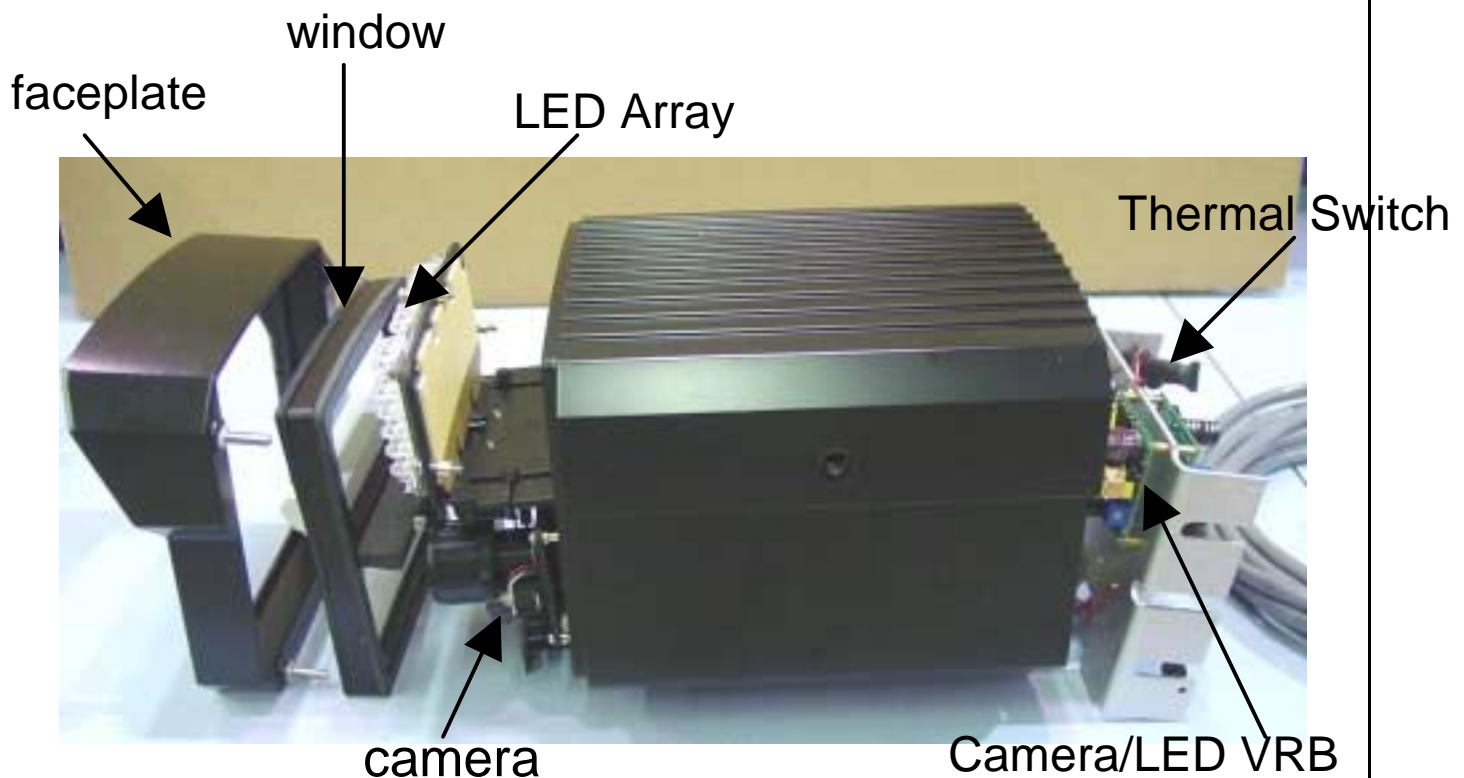

FIGURE 1
Module Location Diagram

2. INPUT POWER / VIDEO OUTPUT CONNECTIONS

The camera unit is pre-connected with two electrically isolated power boards for 24V ac or 12V dc operation with no wiring change or wiring polarity. **See Figure 2-1 & 2-2** for wiring details.

Note:

Input voltage is 10.5VDC to 40VDC for DC input. The AC input range is 12VAC to 28VAC.

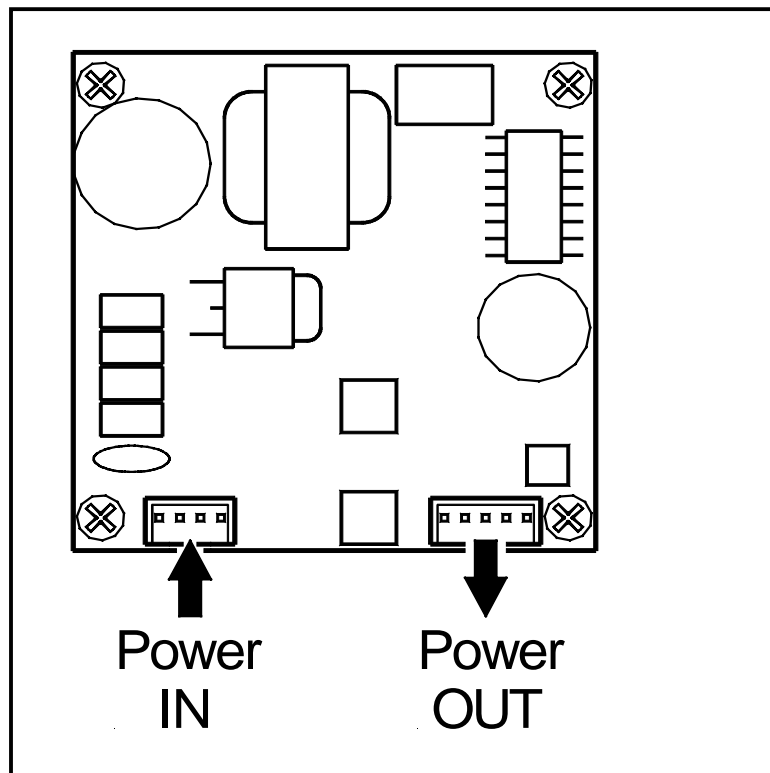

FIGURE 2-1
12VDC or
24VAC
Electrically
Isolated Board

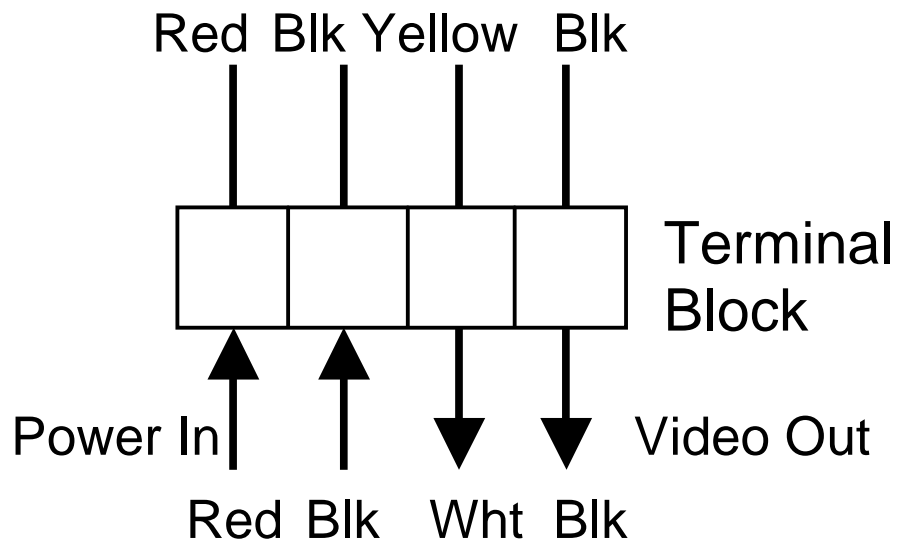

FIGURE 2-2
Terminal Block – Input / Output Wiring

3. MOUNTING – CAMERA HOUSING

Caution: *Install with appropriate screws or drywall anchors to suit mounting surface. Select a suitable location that is protected from accidental damage, tampering and environmental conditions exceeding the camera's specifications.*

See page 19.

Caution: *Ensure the selected location is protected from falling objects, accidental contact with moving objects, and unintentional interference from personnel. Follow all applicable building codes.*

☞ The following installation guidelines must be followed:

- Locate the camera such that it cannot be easily interfered with, either intentionally or accidentally.
- Select a mounting surface capable of supporting the combined weight of the camera and mounting hardware under all expected conditions of vibration and temperature.
- Secure all cabling.
Installations on drywall must use four #12 screws and #12 drywall plugs or superior connection method.

Attach the front faceplate and the rear cover, ensuring that the gaskets are properly seated, no wires are crimped, and the photocell is not dislodged.

Bolt the camera's mounting bracket to the selected mounting surface. (Note: Use the bracket as the hole template, an extra large hole may be required if the cable is going through the bracket.)

Feed the power/video cable through the hole in the mounting bracket and attach the camera with the two flat head screws.

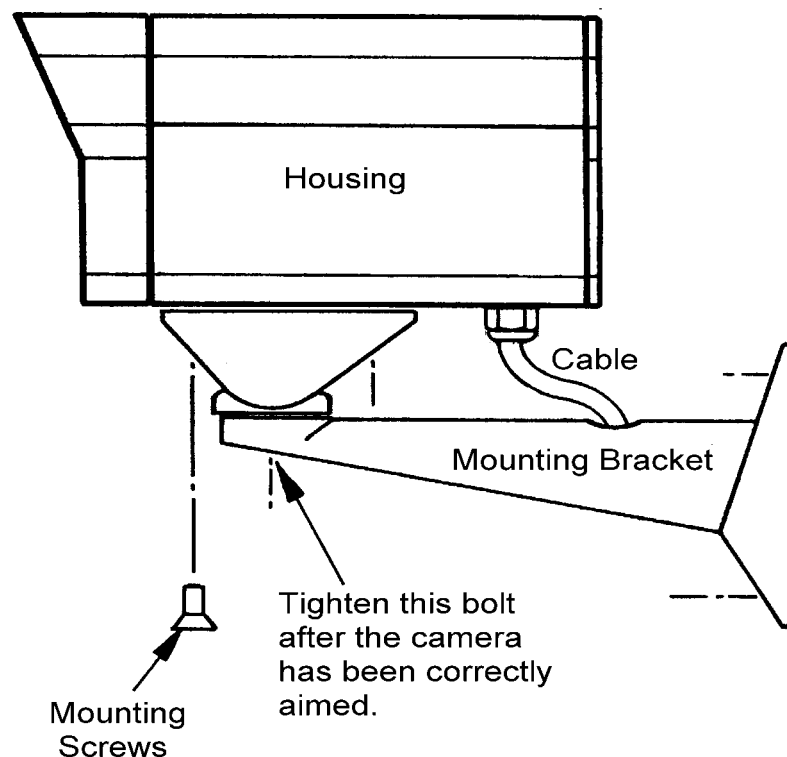

FIGURE 3 – 1
Mounting Details – Camera Housing

4. CAMERA LENS ADJUSTMENTS

For optimum picture quality, the camera lenses should be as close as possible to the inside face of the viewing window, without touching.

Remove the faceplate and the foam lens protector. Make sure the photocell is not dislodged. Loosen the three screws securing the LED/Camera lens assembly bracket to the LED heatsink. Slide out the assembly bracket to its “forward stop” position.

See **Figure 4-1** on page 11.

The lenses' clearance between the window and the front of the lens can be achieved by:

- (a) loosening the screws which secure the Camera / Lens mounting bracket,
- (b) sliding the bracket to its new location, and
- (c) re-tightening the screws.

See **Figure 4-2** on page 11.

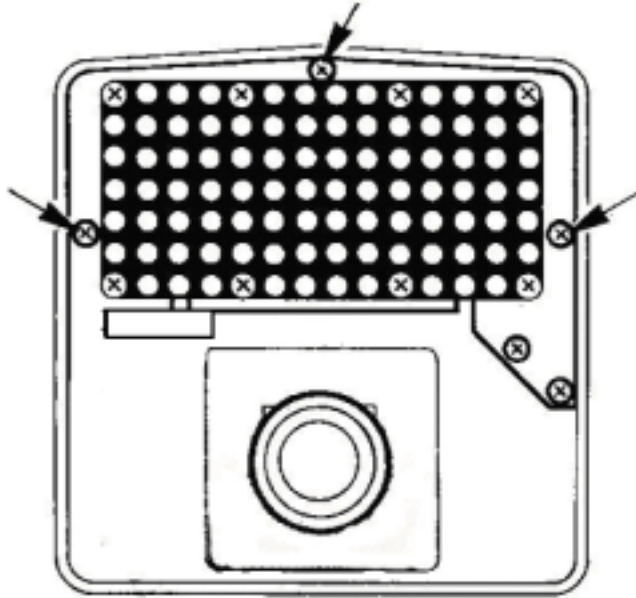

Loosen these three screws These screws are captive and need not be removed, just loosened to the point where the bracket assembly can be moved forward.

FIGURE 4 – 1
LED/Camera Lens Bracket Removal

Loosen these screws to adjust the
Camera / Lens Mounting Bracket

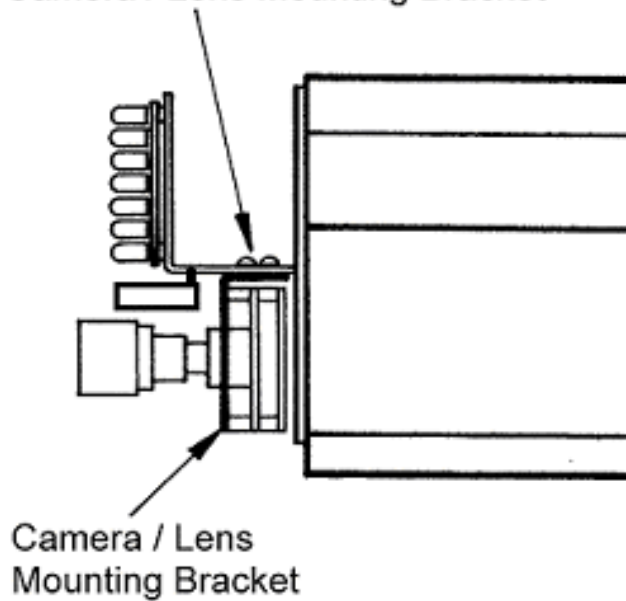

FIGURE 4 – 2
Camera / Lens Mounting Bracket Adjustment

4.1 Vari Focal and “Auto-Iris” Control Adjustments

Step 4.1.1 - Loosen the lens set screws for focus/zoom adjustments.

See **Figure 4-3** on page 13.

Step 4.1.2 - The set screw marked **N** $\longleftrightarrow \infty$ is used for image focus.

Step 4.1.3 - The set screw marked **T** \longleftrightarrow **W** is used for telephoto or wide-angle settings.

Step 4.1.4 - Re-tighten the set screws after focus adjustments have been completed.

Step 4.1.5 - Locate the “Auto-Iris” adjustment controls as shown in **Figure 4-4** on page 14 and as per Table **A** on page 14.

Step 4.1.6 - After adjustments are complete, re-install the LED/Camera lens assembly bracket back onto the LED heatsink.

Loosen this set screw
for Focus Adjustment.

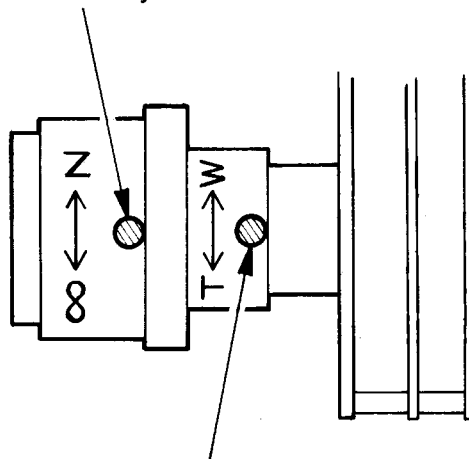

Loosen this set screw for
Telephoto or Wide Angle
Adjustment.

FIGURE 4 – 3 Lens Focus Adjustment

5. LED ARRAY - POWER ADJUSTMENTS

If adjustment needed, remove the rear cover for access to the VRB. The **EX30/38** needs to be powered-up while making the LED power adjustments. Cover or adjust the photocell to turn the LEDs “ON” (850nm LEDs will have a slight red glow while 940nm LEDs are covert).

Adjust the LED power if they are too bright or too dim. Refer to **Figure 5-1** on page 13.

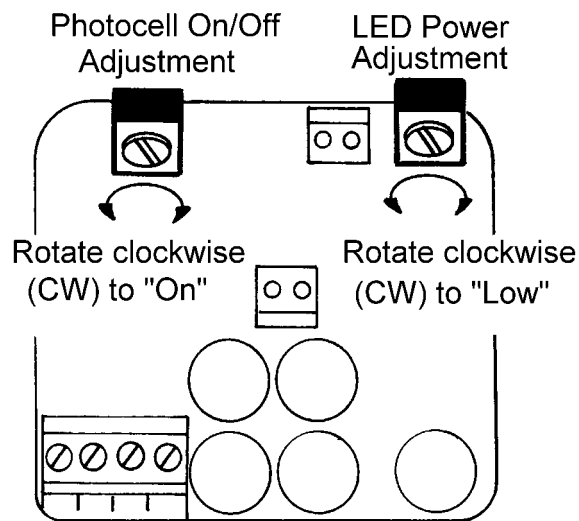

FIGURE 5-1
LED Power and Photocell On/Off Adjustments

For LED power adjustment, rotate clockwise (CW) for “Low” and counter-clockwise (CCW) for “High”.

For photocell “On/Off” light-level adjustment, rotate clockwise (CW) for “On” and counter-clockwise (CCW) for “Off”.

6. WINDOW DEFROSTER UNIT

The EX82 is integrated with a defrosting unit for warming the window and camera during cold weather. A fan is built-in to circulate the hot air from the LED illuminator to warm up the internal window. A thermal switch is used to turn the LED array on and off as a heat source. There are no adjustments to the defroster unit. All settings are preset at the factory.

The LED array may be on during the daytime when the outside temperature is cold. The camera operation is not affected. The fan is always on to circulate the air.

Defrosting Specifications (Approximate):

Fan: 12V, 0.7W, 2 CFM

Defroster on (outside ambient): below $50^{\circ}\text{F} \pm 8^{\circ}\text{F}$
(Approx.)

Defroster off (outside ambient): above $68^{\circ}\text{F} \pm 8^{\circ}\text{F}$
(Approx.)

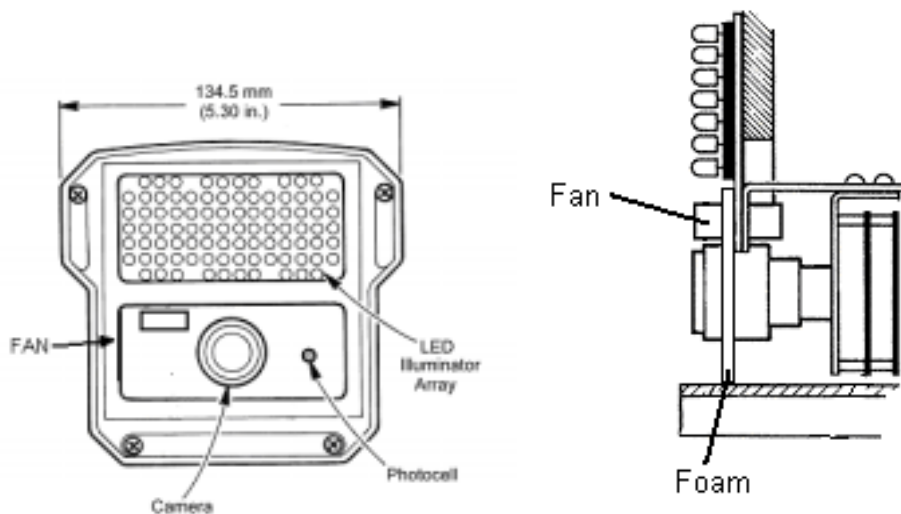

FIGURE 6 – 1 Window Defroster

7. CAMERA RE-ASSEMBLY

Make sure all wires are properly connected and tightened into the terminal blocks, all holes are sealed against moisture penetration, and all mounting screws are tight. The fan airway must not be blocked for proper operation.

Step 8.1 - Slide the rectangular foam pad over the camera lenses. Make sure the pad is snug and as close to the faceplate viewing window as possible and the photocell is secure with an unobstructed view. The foam should not be touching the fan blades and inserted at least half way down so that the air can come to the front window. See figure 6-1.

Step 8.2 - Attach the faceplate and the rear cover to the camera housing. The foam strip on the window assembly should go straight down against the fan.

Step 8.3 - Tighten the camera's adjustable mounting bracket after the desired viewing angle has been determined.

Step 8.4 - Power-up the camera and check its operation.

8. TROUBLESHOOTING GUIDE -CAMERA

<i>PROBLEM</i>	<i>POSSIBLE CAUSE</i>	<i>LIKELY SOLUTION</i>
<p>No Video</p>	<p>1. <u>Power Supply</u>:</p> <p>- Connections</p> <p>-Voltage Range...</p> <p>2. <u>Video Connections</u></p>	<p>Check the input power connections at the terminal block, ensuring no wires are loose.</p> <p>The supply range is: 17 – 28V ac OR 15 – 30V dc. Measure the voltage at the terminal block.</p> <p>Determine if the wiring polarity at the “Video Connector” terminal block is correct. Check BNC connector.</p> <p>If still no video, connect the camera directly to the</p>

<p>Poor Picture Quality</p> <p>Dim Image</p> <p>Snowy Image</p>	<p>Iris closed</p> <p>Poor Video Signal</p> <p>Noisy Power Supply</p>	<p>monitor. Check the video signal. If okay, the problem is with the interconnections.</p> <p>If still no video, contact Extreme CCTV. See the inside front cover of the Service Manual for contact information.</p> <p>Increase iris level on lens</p> <p>Ensure the video cable is correctly matched and terminated with 75 ohms at each end. Make sure the video cables are of similar types.</p> <p>Check all power connections.</p>
--	---	--

<p>Horizontal Scan Lines, Rolling Up or Down</p>	<p>Ground Looping on video cable</p>	<p>Relocate or replace the power supply.</p> <p>Check the coax cable shield is not touching "ground", e.g. at the couplings.</p> <p>An electrically isolated circuit board or isolation transformer may be required.</p>
<p>Negative, scrambled, or faded image</p>	<p>Low voltage</p>	<p>Check voltage at input power cable. Must be >12V dc or >17V ac.</p> <p>Video leads reversed connection.</p>

9. TROUBLESHOOTING GUIDE – LEDs

<i>PROBLEM</i>	<i>POSSIBLE SOLUTION</i>
Fuse Blows	<ul style="list-style-type: none"> - Check the fuse rating. - Check for shorting between the housing and the input power wires.
Don't know if LEDS are "ON"	<ul style="list-style-type: none"> - 850nm LEDS will have a faint red glow when "ON". 940nm LEDS are covert. - Aim the LEDS directly at an IR sensitive camera, or use a mirror to see the lights through the EX82DXL B/W camera, or wait for the LEDS to warm up (two minutes).
LEDs are not "ON"	<ul style="list-style-type: none"> - Cover the photo sensor to activate power to the LEDS (up to 30 seconds delay for activation). - Adjust the photocell's variable resistor towards the "ON" position. - Adjust power to the LEDS.
LEDs are not turning "OFF" when sufficient ambient light is present	<ul style="list-style-type: none"> - Make sure the photo sensor is not covered or hidden behind any object. - Adjust the photocell's variable resistor towards the "OFF" position (up to 30 seconds delay). The LEDS will stay "ON" or "OFF" if the adjustments are at full turn.

10. GENERAL SPECIFICATIONS

Power Consumption:	22W Max.
Input Voltage:	24V ac 12V dc
Enclosure (housing): and extrusion	Aluminum casting
Viewing Window:	¼" Lexan
Dimensions:	130mm H (5.12") 134.5mm W (5.30") 212mm L (8.35")
Window Defroster Fan:	12V, 0.7W, 2 CFM
Defroster on (outside ambient):	below 50 ⁰ F +/- 8 ⁰ F (Approx.)
Defroster off (outside ambient):	above 68 ⁰ F +/- 8 ⁰ F (Approx.)
Weight:	2.2kg (4.9 lbs.)

Subject to change without notice.



Extreme CCTV®

SURVEILLANCE SYSTEMS

Canada 3021 Underhill Avenue,
Burnaby, BC V5A 3C2

USA 3873 - C Airport Way,
PO Box 9754,
Bellingham, WA 98227

tel 1-888-409-2288 (toll free)
1-604-420-7711

fax 1-604-420-3300

e-mail tech@ExtremeCCTV.com

web www.ExtremeCCTV.com

Europe Colbourne Cres.
Cramlington, Northumberland
United Kingdom, NE23 1WB

tel +44(0)1670.730.187

fax +44(0)1670.730.188

DEALER / AGENT: