



---

White Paper

# Installing a Wireless LAN Network Using Power over LAN

**Yuval Berson**

**Product Manager  
Wireless LAN  
PowerDsine Ltd.**

Revision 001  
Last modified – August 5, 2002

### What is Power over LAN™?

Power over LAN is a revolutionary technology that integrates data, voice and power over standard LAN infrastructure. It is the means to supply reliable, uninterrupted power to Internet Protocol (IP) telephones, wireless LAN access points, network cameras and other Ethernet devices, using existing, commonly used Category 3 (4 pairs) and Category 5 cable infrastructure.

Power over LAN technology saves time and cost of installing separate power cabling, AC outlets and wall warts, as well as eliminates the need for a dedicated UPS for individual devices.

The power delivered over the LAN infrastructure is automatically activated when a compatible terminal is identified, and blocked to legacy devices that are not compatible. This feature allows users to freely and safely mix legacy and Power over LAN-compatible devices, on their network.

The Power over LAN technology is designed in a way that does not degrade the network data communication performance or decreases the network reach.

There are two main implementations of Power over LAN:

**The end-span** – Power over LAN enabled Ethernet switch. Power is supplied directly from the data ports.

**The mid-span** – A patch-panel like device, residing between an ordinary Ethernet switch and the terminals, often referred to as a “Power Hub”. Power is added on the spare wires, with data uninterrupted.

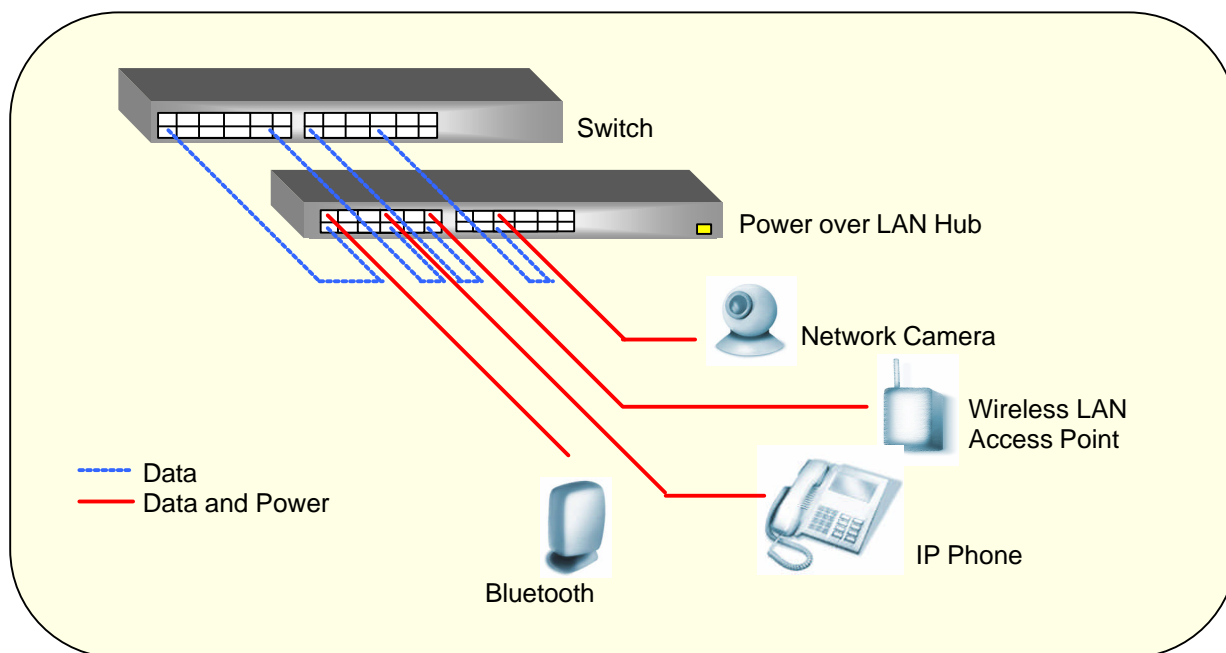

**Figure 1: Architecture of Power over LAN in the Enterprise**



## Wireless LAN and Power over LAN

Wireless LAN technology enables LAN users to free themselves from the cabling constraints imposed by the wired LAN. To do that, WLAN Access Points (AP) are installed to provide the link between the wired LAN and the wireless world. These Access Points need to be powered. Traditionally, the Access Points required AC outlets into which their various adapters were connected.

The Access Points are traditionally installed in open high places, such as corridor ceilings, airport or lecture halls, etc. The adding of power infrastructure was a costly and long affair, requiring dedicated electricians team for pulling of power cables, changes of building plans and safety approvals.

Once operating, each Access Point was connected to a specific electric net, which if down, meant an appearance of annoying "holes" in the WLAN network coverage.

Power over LAN technology enables WLAN access points to be powered over the network-cabling infrastructure, thus avoiding the need for separate power and data cable infrastructure and costly AC outlets near the Access Points not to mention the removal of the electricians from the team.

By allowing the Access Points to be installed where they are most effective and not where the AC sockets are, the actual number of costly Access Points may also be reduced, further reducing the Wireless LAN implementation costs.

There are additional key benefits for Power over LAN in WLAN:

- **Simple means for resetting Access Points**

Access Points are complicated devices, which tend to need resetting from time to time. A "silent" Access Point, once discovered to require a reset, forces the IT manager to locate the Access Point, reach it, and then reset it. By using Power over LAN, it is a trivial matter of resetting, via the Access Point's respective Power over LAN port. (Instead of ripping down decorative ceilings.)

- **Simplified radio coverage surveys and easy changes to Access Point positions as needed.**

Altering an Access Point position, no longer requires a new AC installation. It is even possible to experiment with the Access Point position to achieve ultimate coverage results.

- **UPS backup for the WLAN network**

By backing up of the Power over LAN Midspan in the communication room, the entire WLAN network can become more reliable and continue operation during a power outage.

- **Assured safety with advanced line terminal detection**

Line detection is the technology which enables safe installation without worrying about high voltage damages to laptops, desktops and other non-power ready devices, due to a misplaced connection.

A faulty Access Point can be detected and shut down preventing damage to expensive switches and patch panels in the Ethernet network. The line detection is one of the reasons the Power hub is much more than an intelligent power source.

### Installing a Wireless LAN Network Using Power over LAN

Enterprise Wireless LAN is being installed today in many different environments. Most common among these:

- Healthcare, hospitals
- Large Enterprise, mainly finance
- Universities, schools, training sites
- Retail stores, warehouses
- Trade shows and branch offices
- Hospitality hotspots (hotels, airports, restaurants, etc.)

There are differences in the requirements from the WLAN system for each type of environment. A university campus installation, with the need for minimum maintenance and high bandwidth, is very different from a warehouse installation, with the need for durability and security, and so on.

This paper focuses on the approach to optimize the WLAN network with Power over LAN.

Fortunately, all WLAN installations, in most environments, share a very similar infrastructure design.

The Ethernet lines run from the network switch, usually through a patch panel, out of the communication room and connect to the access points (See figure 2). Adding Power over LAN enables the Access Points to be powered through the same cabling infrastructure, providing the most cost effective solution.

When the switch is already installed, the simplest means to add Power over LAN is by adding a dedicated Power over LAN hub.

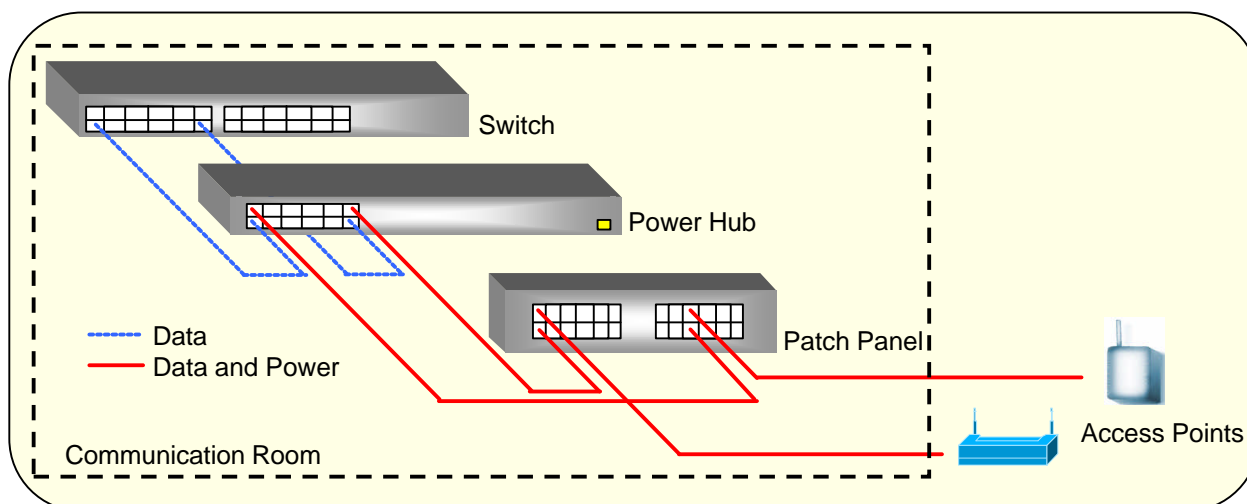

**Figure 2: Installing WLAN with Power over LAN**

### How to Select the Appropriate Power over LAN Hub

Once installed, the Access Points' Ethernet cabling is pulled to the communication rooms, where the switches (and Power hubs) are installed.

The port density of Access Points that reach a specific communication room depends on the following parameters:

- Ethernet cable maximum length, which is 100 m (330 ft)
- Number of potential WLAN users, which may require over coverage of radios, in order to maintain bandwidth.
- Reach of radio coverage, especially in an 802.11a installation.

From PowerDsine's multi-site experience, one can find three typical port densities in the communication room:

1. A multi-user university / enterprise environment - **8 to 10** Access Points pulled to the Communication room.
2. Smaller or spread installations – **3 to 4** Access Points pulled to the Communication room.
3. Remote sites and single Access Point installations – **1 to 2** Access Points pulled to the Communication room.

PowerDsine® Power Hubs, dedicated for wireless LAN, are the 1,6 and 12 port units. These units fit exactly the above port densities needs.

In order to optimize the distribution of Power hubs, the following guidelines should be followed:

#### 1. Concentrating Access Points optimize the installation

Rather than attempting to install the shortest cabling, try to pull WLAN cabling to a single communication room rather than distributing small number of Access Points in every communication room. This will enable a selection of a Power Hub with a higher port density and save rack space and installation costs.

See the example, presented in Figure 3.

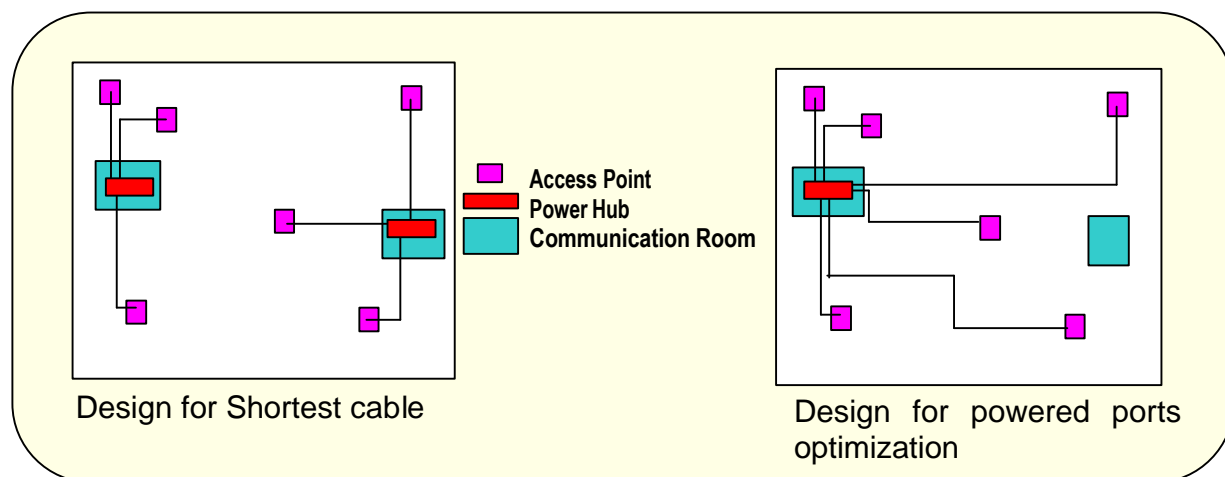

**Figure 3: Concentrating of Access Points to Optimize the Installation**



## 2. Selecting the appropriate Power Hubs

Once the number of Access Points per communication room has been estimated, the following table is applied in order to select the appropriate Power over LAN products:

Access Point Ports Density	Power Hub to use	Recommendations
1-2	1-port	
3-4	6-port	Save 2 ports for expansion
8-10	12-port	Save 2 ports for expansion
11->	12-Port and additional units following the same guidelines.	

## 3. Room for Expansion

In a similar fashion to Ethernet ports, 1 to 2 spare ports should be available for future growth, in case the WLAN network requires an additional Access Points, or the number of users has increased.



## **Power over LAN Installation Tips**

The following are some tips, based upon PowerDsine multi-site experience:

- **Power all Access Points using Power over LAN.** It may be tempting to use some AC outlets that are available, apparently to save some installation costs. This has the following implications:
  - ☞ Power Hubs provide a simple convenient means to reset Access Points, which are hidden or hard to reach.
  - ☞ The “vacuum cleaner” effect – cleaning personnel unplugging Access Points, to use an existing AC outlet, as they are easy to find, creating coverage breaks in the network.
  - ☞ Maintaining UPS capability. This creates a back up capability of the entire WLAN network (by backing up the Power Hub).
- **Install all hubs in communication rooms.** To minimize tampering with the units and enable central management. 6-port and 12-port units should preferably be rack mounted. 1-port hubs can be placed on top of equipment, or wall mounted.
- **Use color-coding for powered WLAN cabling,** to indicate that these cables are not to be touched by maintenance personnel.
- **Use the per-port LED indications** on the Power Hubs, to verify the state of the powered devices:
  - ☞ Green (Power Active) LED indicates that power is being provided. This is a good way to know that an Access Point is connected correctly.
  - ☞ Orange (Power not Active) LED indicates that a non-powered device is connected to this port or that the Access Point may be malfunctioning. This may also indicate that an installation error has occurred. The uniqueness of the PowerDsine Power Hub is that this is a completely safe state, though it is recommended to check the cause.



## PowerDsine Power Hub Family

PowerDsine family of Power over LAN midspan devices, with hundreds of thousands of ports already deployed by PowerDsine and by our satisfied partners, provides the most field-proven reliable solution.

PowerDsine provides a full line of Power over LAN midspan devices, from to a 24-port device intended mainly for Voice over IP applications such as the **Cisco 79xx IP-phone** to a single port hub, planned for wireless LAN and network cameras.

PowerDsine Power Hubs, intended for Wireless LAN Access Points such as the **Cisco Aironet 350** and **Cisco Aironet 1200** family, are the 1, 6 and 12-port units.

### PowerDsine 6012 12-Port Power Hub



- 12-port power Hub
- Full 802.3af compliance
- Powers Cisco Inline power devices
- SNMP management option
- 1U high, 19 – in. rack mountable
- Safe Detection algorithm
- LED Status indications

### PowerDsine 6006 6-Port Power Hub



- 6-port power Hub
- Full 802.3af compliance
- Powers Cisco Inline power devices
- SNMP management option
- 1U high, 19 – in. rack mountable
- Safe Detection algorithm
- LED Status indications

### PowerDsine 4001 1-Port Power Hub



- 1-port power Hub
- Full 802.3af compliance (6001 series)
- Powers Cisco Inline power devices
- Safe Detection algorithm
- LED Status indications
- Wall mountable or free standing



### Remote SNMP Management of The Power Hubs

A unique option of PowerDsine's Power Hubs is SNMP remote management. This feature allows for remote control of the Power hub technology and the gathering of essential telemetry, collected by the units. Using the SNMP remote management enables central control of multi building installations enabling an immediate alert and response to a change in the well being of Access Points in the field.

Main features of remote management:

- On/Off control for resetting units

Enables the IT manager to remotely reset a "silent" Access Point, which would not respond otherwise. This important feature prevents the need to go to far-away communication rooms in a spread installation.

- Security power-off shut down of the network

Some times it may be necessary to quickly halt the entire WLAN network in the campus. A single command will stop all power remotely to the network.

- Telemetry of Access Point state

A maintenance dream: the remote management feature will alert to a change in the status of the Access Point, fall in power consumption, disappearance etc. to identify discontinuities in the WLAN network coverage.

- Telemetry of power consumption

Collects power consumption information, to decide the appropriate UPS for your network, saving cost of needless UPS power. Get information on standby versus active Access Points.

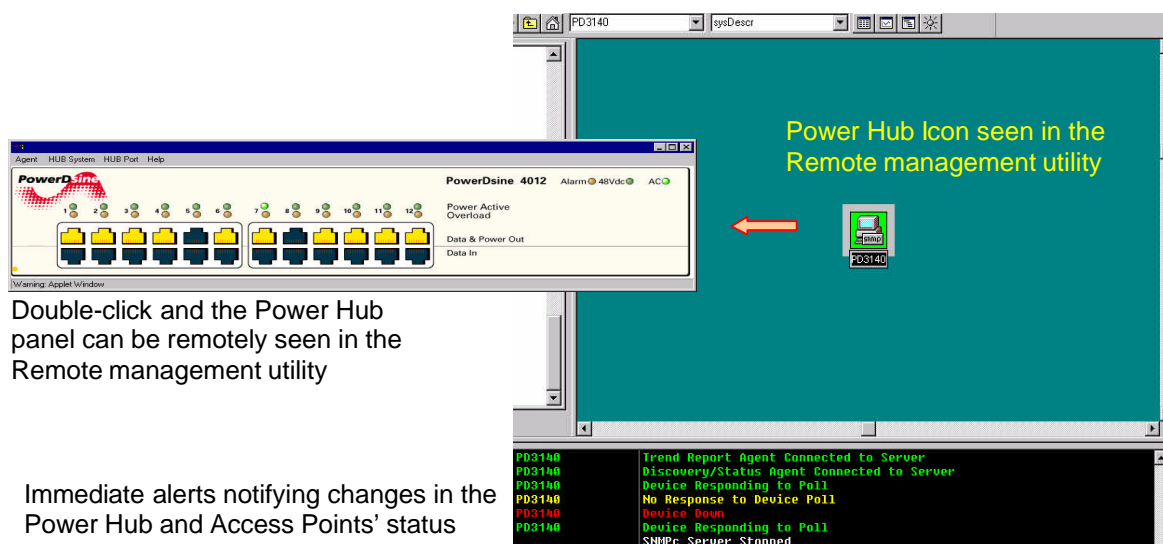

Double-click and the Power Hub panel can be remotely seen in the Remote management utility

Immediate alerts notifying changes in the Power Hub and Access Points' status

Figure 4: SNMP Management Screen



## Installing a Wireless LAN network Using Power over LAN

---

### Conclusion

This paper serves as a guide for the optimization of a Wireless LAN installation with Power over LAN. Using the information provided here will assure the installer, user, or IT manager an easier to set-up and maintain Wireless LAN network. Installation becomes simpler, more reliable and outright cheaper.

PowerDsine Power Hubs family for Wireless LAN provides IT managers the simplest, safest, most cost effective solution for installing the Wireless LAN network. The advanced features of the Power Hubs also vastly simplify the on-going maintenance of the WLAN network, enabling reliable, continuous operation with minimum downtime. The paper discussed the means to maximize the power Hubs benefits.

The SNMP remote management capability enables remote control of the Power hub technology and the gathering of essential telemetry, collected by the units. Central control of a multi-building installation for an immediate alert and response to a change in the status of an Access point, or other powered devices.

The advanced detection mechanism, as well as the full IEEE 802.3af compliance today, guarantees the PowerDsine Hub interoperability with many powered devices.

*For more information on the PowerDsine Power over LAN™ Hub products and our additional 802.3af compliant products, as well as the IEEE 802.3af standard for DTE Power via MDI, look us up at: [www.powerdsine.com](http://www.powerdsine.com)*

**International Headquarters**  
1 Hanagar St., P.O. Box 7220  
Hod Hasharon 45421, Israel  
Tel: +972-9-7755100  
Fax: +972-9-7755111  
sales@powerdsine.com

**Europe**  
PowerDsine Europe  
Handelstr. 21  
D-61130 Nidderau, Germany  
Tel: +49-6187-900-849  
Fax: +49-6187-292-848  
europe@powerdsine.com  
PowerDsine Ltd.

**Japan**  
PowerDsine Japan  
19F Bunkyo Green Court Center Office  
2-28-8 Honkomagome, Bunkyo-Ku  
Tokyo, 113-6591 Japan  
Tel: +81-3-5978-1814  
Japan@powerdsine.com

**North America**  
PowerDsine, Inc.  
1865 New Highway  
Farmingdale, NY 11735, USA  
Tel: +1-6 31-756-4680  
Fax: +1-6 31-756-4691  
sales@powerdsineusa.com

PowerDsine Sweden  
Ekbackvagen 28  
16869 BROMMA, Sweden  
Tel: +46(0)8-555-361-46  
Fax: +46(0)8-555-361-08  
sweden@powerdsine.com

**Korea**  
PowerDsine Korea  
Rm 1117 Daewoo Maison Officetel, 750-  
1 Janghang-dong, Ilsan-ku, Koyang  
City, Kyunggi-do, Korea  
Tel: +82-31-817-6447  
Fax: +82-11-717-9974  
Korea@powerdsine.com

The information contained herein is believed to be accurate and reliable at the time of printing. However, PowerDsine Ltd. cannot assume responsibility for inadvertent errors, inaccuracies, omissions, or subsequent changes. In the interest of continuous product improvement, and in view of our commitment to enhance quality and reliability, PowerDsine Ltd. reserves the right to make changes to products and to their specifications at any time. The company is also committed to keeping the standards of the IEEE 802.3af. It is suggested that before embarking on any product design based on details in this document, the latest and most current information should be obtained from PowerDsine. Contact the Technical Support Department Tel: +972-09-7755123 Fax: +972 09-7755112, email: techsupport@powerdsine.com. No rights to any PowerDsine Ltd. intellectual property are licensed to any third party either directly, by implication or by any other method. Power over LAN™ and PowerDsine are trademarks of PowerDsine. All other trademarks are the property of their respective owners.

© 2000, 2001, 2002 Patent Pending