



Extreme CCTV[®]

SURVEILLANCE SYSTEMS

Precision Engineered Opto-Electronics[™]

INSTALLATION INSTRUCTIONS

EX26LED

Infrared Illuminator

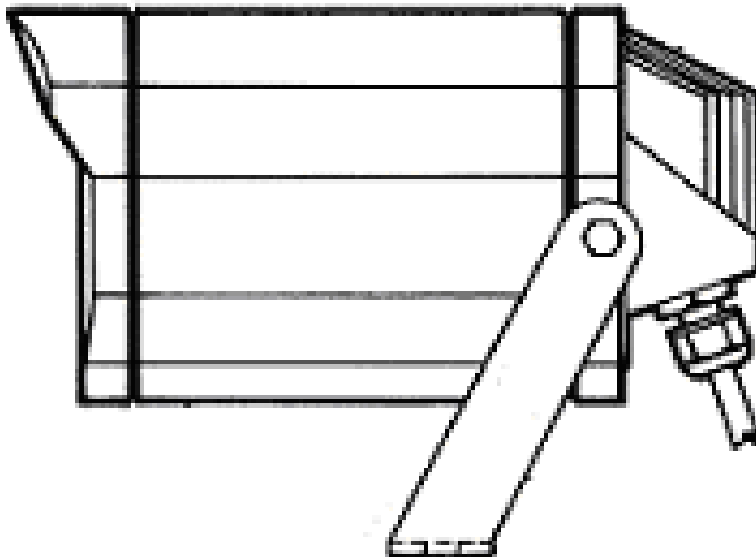

www.ExtremeCCTV.com

Toll free: 1-888-409-2288
MAN-26LED-01



IMPORTANT

For best results, please read this Instruction Booklet prior to installing the **EX26LED** illuminator.



WARNING !

CSA Certified / UL Listed CLASS 2 power adaptors must be used in order to comply with electrical safety standards.



Extreme CCTV®
SURVEILLANCE SYSTEMS
Made in Canada

12 Vdc, 12W(max)

24 Vac, 60 Hz, 12W(max)

Certified to:

UL 50 / UL 2044

CSA C22.2 No. 0-M1991

CSA C22.2 No. 1-M94

CSA C22.2 No. 94-M91

CSA Type 4X / NEMA 4X

CSA C22.2 No. 94-M91

NEC Class 2 Limited Power Circuit See Installation

Instructions For Proper Connections



EU Directives covered by this declaration:

72/9/EC Low Voltage Directives

89/336/EEC Electromagnetic Compatibility Directive

This installation should be made by a qualified service person and conform to all local codes.

EXTREME CCTV® will not be responsible for injuries or damages resulting from the improper installation or use of any illuminator sold by **EXTREME CCTV®**, their agents, distributors or dealers.

INDEX – EX26

	<u>Page</u>
Description	1
Unpacking	2
Parts List	2
Items Required for Installation	2
Mechanical Specifications	3
Initial Preparations	5
Guidelines	6
Section 1. Voltage Setting	7
Section 2. Adjustments – Illuminator	10
Section 3. Illuminator Mounting	12
Section 4. Troubleshooting - Illuminator	13
Section 5. General Specifications	16

DESCRIPTION

The EX26LED Infrared Illuminator is a versatile short to mid-range illuminator (60 feet / 20 m with 850 nm LED's, at a 30° beam angle). It is encased in a weather-tight cast and extruded aluminum housing and is equipped with a U-bracket for instant installation. As a 12 VDC / 24 VAC unit, it is ideal for existing CCTV installations and new CCTV projects that specify 24 hour surveillance in and around buildings in covert or semi-covert conditions.

A voltage regulator circuit allows for *12V dc* or *24V ac* operation, and a range in between, also providing protection from voltage surge, transient spikes, and reverse voltage.

Contact Extreme CCTV® for information.

- sales@ExtremeCCTV.com
- Tel: 1-888-409-2288 (Toll free NA)

See the Light. Get the Picture.™

UNPACKING

Care should be taken when unpacking. Check the parts list and confirm all items have been located. Inspect the equipment thoroughly to ensure nothing was damaged in transit.

Contact Extreme CCTV if a problem is noted.

- quality@ExtremeCCTV.com
- Tel: 1-604-420-7711 or

see the rear of the booklet for contact numbers.

PARTS LIST (items supplied with unit)

- *EX26* illuminator assembly
- Installation Instructions
- “U” shaped Mounting Bracket

ITEMS REQUIRED FOR INSTALLATION

(not supplied with unit)

- Phillips screwdriver
- 3mm Allan key
- Optional heavy duty “L” mounting bracket or die-cast aluminum mounting bracket (contact Extreme CCTV for details and prices)
- Hardware for illuminator mounting (bolts, etc.)

EX26 MECHANICAL SPECIFICATIONS

(See Section 6 - General Specifications, for additional information)

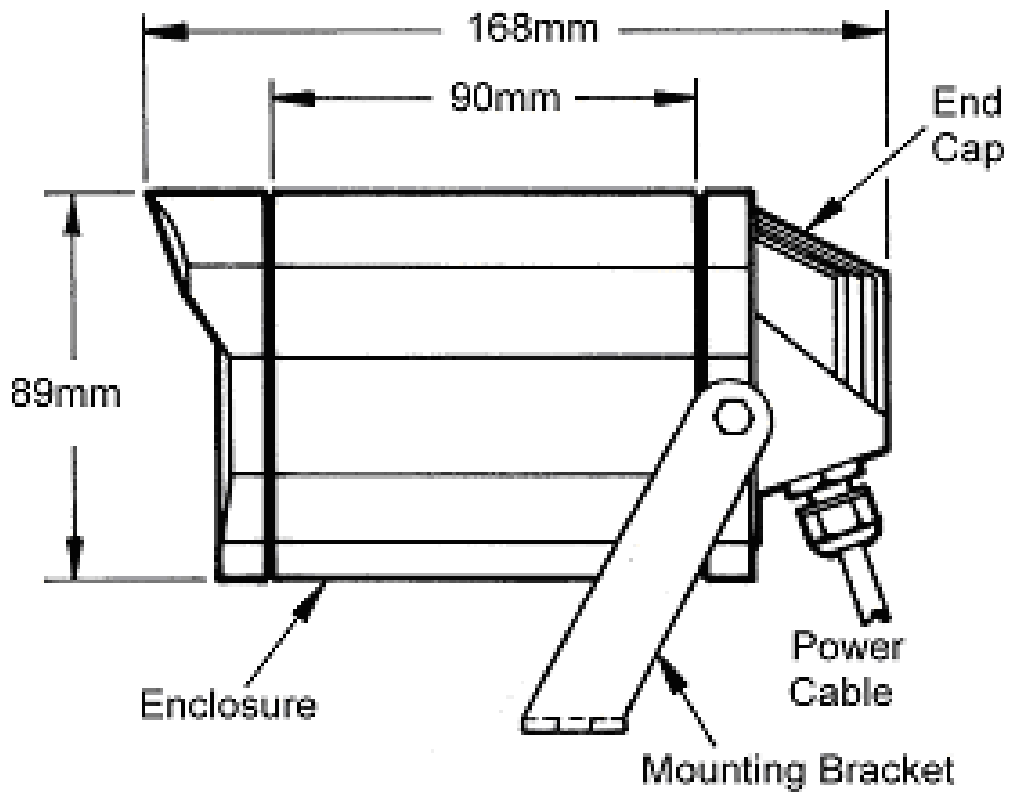

Side View

EX26 MECHANICAL SPECIFICATIONS

(See Section 6 - General Specifications, for additional information)

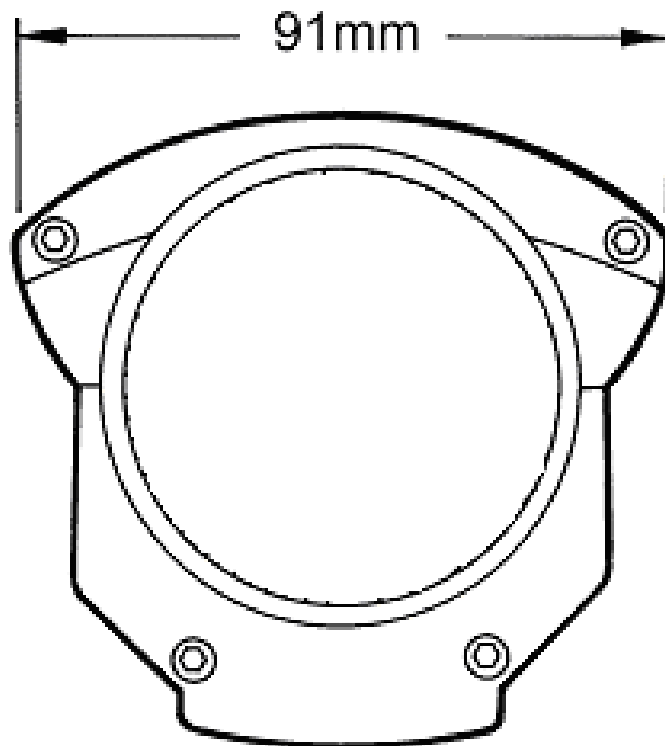

Front View

INITIAL PREPARATIONS

- Determine the operating voltage at the installation site. The illuminator has been pre-wired at the factory for 24V ac operation. *Section 1 – Voltage Setting.*
- All illuminators have been tested prior to shipment. After the wiring has been reconnected, it is advisable to check the illuminator's operation before installation.

Select a suitable location that is protected from accidental damage, tampering, and environmental conditions exceeding the illuminator's specifications.

Caution: The selected mounting location should not place the illuminator in a situation where its environmental specifications could be exceeded. Ensure the selected location is protected from falling objects, accidental contact with moving objects, and unintentional interference from personnel. Follow all applicable building codes.



The following installation guidelines must be followed:

- Locate the illuminator such that it cannot be easily interfered with, either intentionally or accidentally.
- Select a mounting surface capable of supporting the combined weight of the illuminator and mounting hardware under all expected conditions of vibration and temperature.
- Secure all cabling.
- Installations on drywall must use a ¼” bolt and drywall butterfly type anchor or superior connection.

GUIDELINES

Two basic requirements must be met before the *EX26* can be installed.

1. Voltage Setting
2. Illuminator Wiring & Settings

Sections 1 and 2 will guide the installer through these settings and adjustments.

1. VOLTAGE SETTING

The *EX26*, when shipped, is connected for 24V ac operation.

Note: Input voltages between 13.5 and 28V, ac or dc, will work in the 24V ac input setting.

Step 1.1 - If 12V dc operation is required, remove the screw located at the rear of the housing. (**Figure 2-1**)

Step 1.2 - For 24Vac operation:
Power is **red or black**
Refer to **Figure 1-1** on page 8.

For 12V dc operation: Power is **black** (GND) and **red** (+ dc).
Refer to **Figure 1-2** on page 9.

Step 1.3 - Before closing the end, ensure the gasket is seated properly on the enclosure (flat against the edge). Close the end and tighten the screw.

Step 1.4 - Test the illuminator for proper operation.

See Section 2, **Figures 2-1** if access to VRB is required.

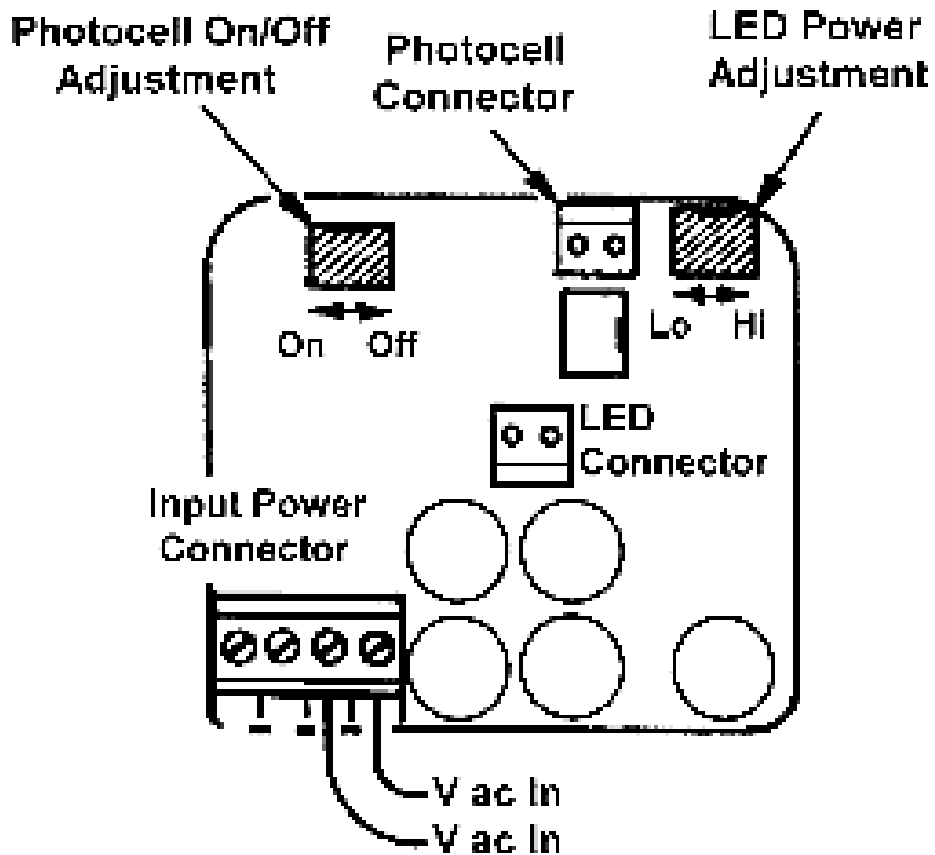

FIGURE 1 – 1
Terminal Block
24V ac Connections
(as shipped)

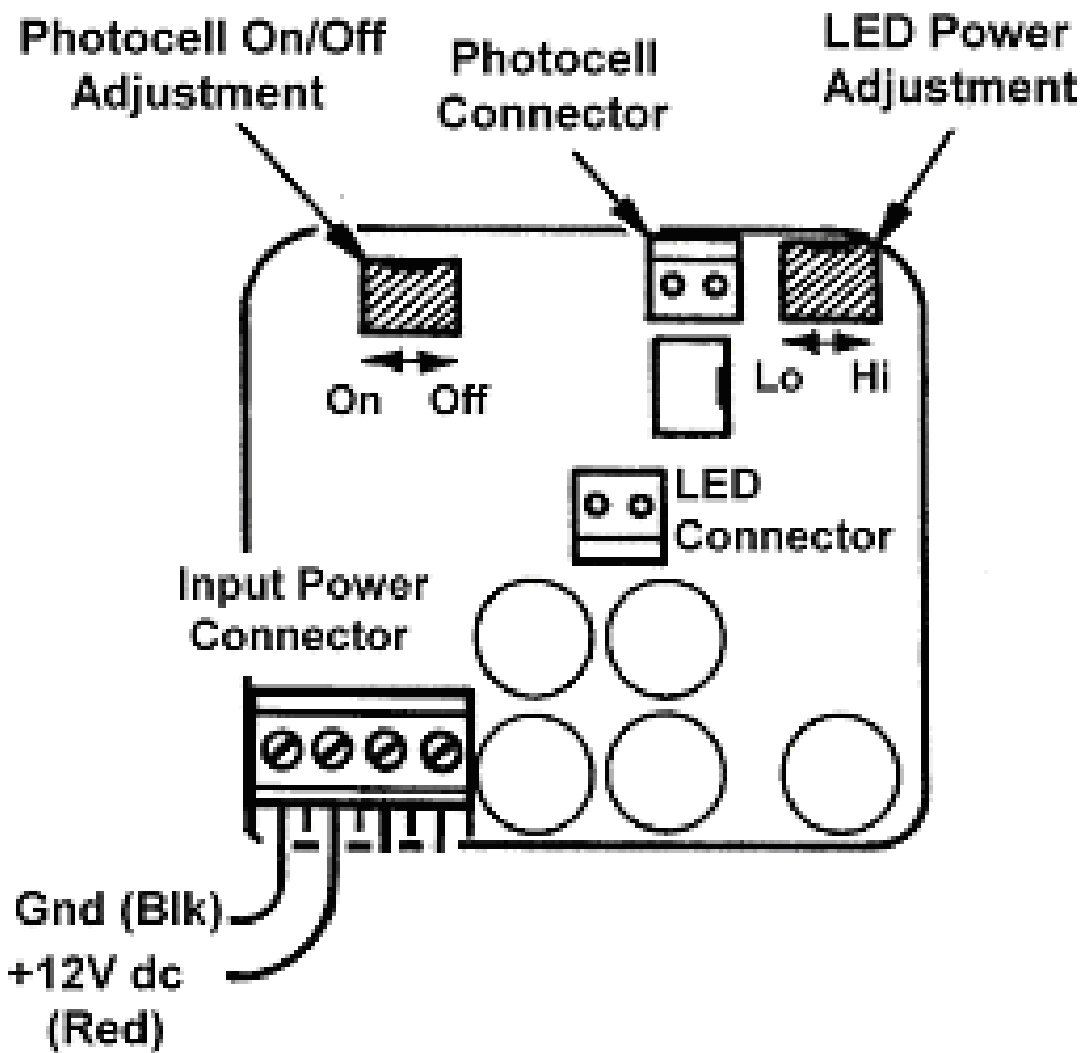

FIGURE 1 – 2
Terminal Block
+12V dc Connection

2. ADJUSTMENTS - ILLUMINATOR

For optimum picture quality the illuminator brightness can be adjusted to match the camera. It would be beneficial for the installer to have a connected IR sensitive camera during this adjustment phase.

The following steps show the installer how to access the Illuminator/LED board.

Step 2.1 - Disconnect the power source to the illuminator.

Step 2.2 - Remove the four cap screws with a 3mm Allan key. See **Figure 2-1** on page 11.

- Step 2.3 - Carefully slide out the rear housing from the main enclosure. Make sure the gasket remains with the rear section..
- Step 2.4 - Make the necessary adjustments as per **Figures 1-1** to **1-2** on pages 8 to 9 respectively.
- Step 2.5 - Carefully slide rear section back into the main enclosure and re-install the cap screws.

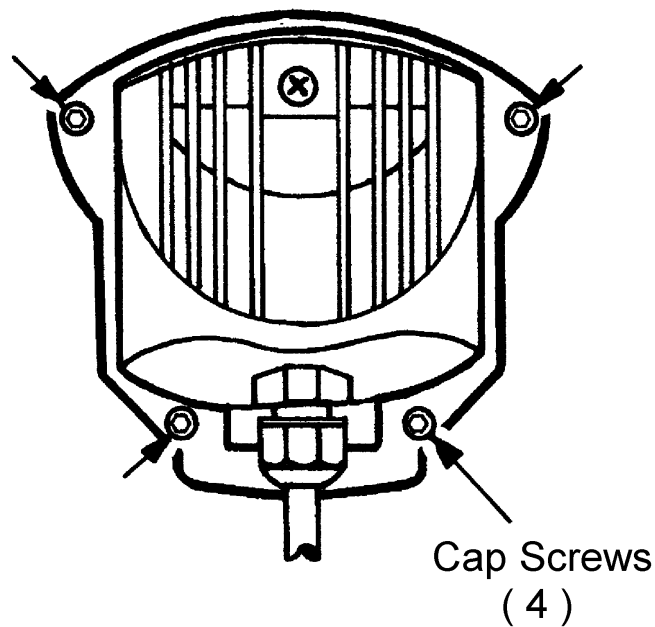
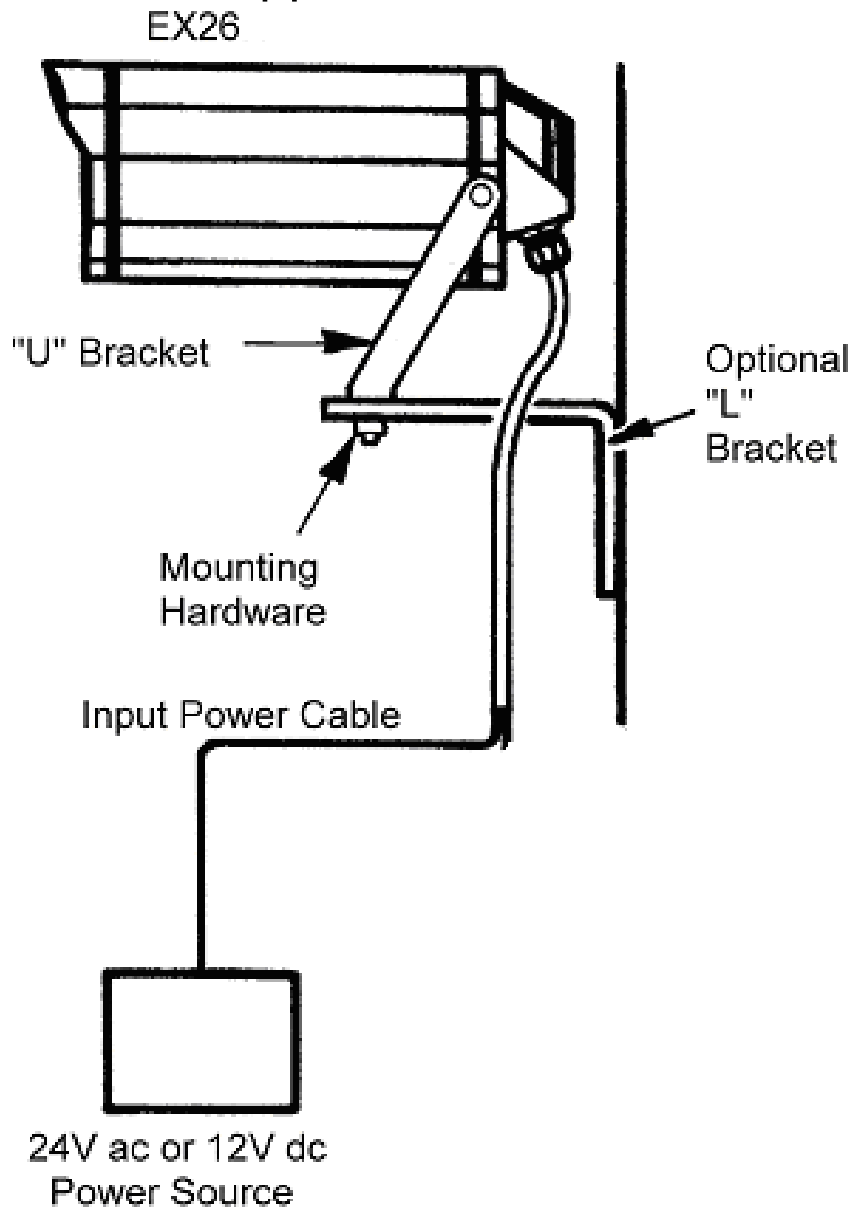

FIGURE 2 – 1
Rear Housing Removal

3. ILLUMINATOR MOUNTING

The EX26 can be mounted using the optional "L" bracket or the supplied "U" bracket.



4. TROUBLESHOOTING GUIDE – LEDs

<i>PROBLEM</i>	<i>POSSIBLE SOLUTION</i>
Fuse Blows	<ul style="list-style-type: none">- Check the fuse rating.- Check for shorting between the housing and the input power wires.
Don't know if LEDs are "ON"	<ul style="list-style-type: none">-850nm LEDs will have a faint red glow when "ON".-940nm LEDs are covert.-Aim the LEDs directly at an IR sensitive camera, or use a mirror to see the lights through the EX35 camera, or wait for the LEDs to warm up (two minutes).

<p>LEDs are not “ON”</p>	<ul style="list-style-type: none">- Cover the photocell to activate power to the LEDs (up to 30 seconds delay for activation).- Adjust the photocell’s variable resistor towards the “ON” position.- Adjust power to the LEDs.
<p>LEDs are not turning “OFF” when sufficient ambient light is present</p>	<ul style="list-style-type: none">- Make sure the photocell is not covered or hidden behind any object.- Adjust the photocell’s variable resistor towards the “OFF” position (up to 30 seconds delay). The LEDs will stay “ON” or “OFF” if the adjustments are at full turn.

Note:

5. GENERAL SPECIFICATIONS

LED Type.....High Perf. 850nm / 940nm

LED Beam Angles60deg. (W), 30deg. (M)

Operational Range.....-50°C to +60°C
(-58°F to +140°F)

Humidity Range Up to 85% (relative)

Power Supply..... 12V dc or 24V ac
(60Hz), 10W

Housing.....Extruded Aluminum

Dimensions 168mm x 91mm x 89mm

Weight..... 1.5 lbs.

Subject To Change Without Notice.



Extreme CCTV®

SURVEILLANCE SYSTEMS

Canada 3021 Underhill Avenue,
Burnaby, BC V5A 3C2

USA 3873 - C Airport Way,
PO Box 9754,
Bellingham, WA 98227

tel 1-888-409-2288 (toll free)

1-604-420-7711

fax 1-604-420-3300

e-mail tech@ExtremeCCTV.com

Web www.ExtremeCCTV.com

Europe Colbourne Cres.
Cramlington, Northumberland
United Kingdom, NE23 1WB

Tel +44 (0) 1670.730.187

Fax +44 (0) 1670.730.188

Dealer / Distributor: