



**Extreme CCTV™**  
SURVEILLANCE SYSTEMS

Precision Engineered Opto-Electronics™

# INSTALLATION INSTRUCTIONS

## EX44

Hi-Impact Dome Camera



[www.ExtremeCCTV.com](http://www.ExtremeCCTV.com)

Toll free: 1-888-409-2288  
**MAN-44-04**



## IMPORTANT

For best results, please read this Instruction Booklet prior to installing the **EX44** camera.



## WARNING !

CSA Certified / UL Listed CLASS 2 power adaptors must be used in order to comply with electrical safety standards.

 <b>Extreme CCTV™</b> SURVEILLANCE SYSTEMS Made in Canada		Certified to:	
		UL 50 / UL 2044	CSA C22.2 No. 0-M1991
<b>12 Vdc, 14W(max)</b> <b>24 Vac, 60 Hz, 14W(max)</b>	C US 189936	CSA C22.2 No. 1-M94	CSA C22.2 No. 94-M91
		CSA Type 4X / NEMA 4X	CSA C22.2 No. 94-M91
NEC Class 2 Limited Power Circuit See Installation Instructions For Proper Connections			

This Product Has Been Certified By CSA International To Include the Health Care Facility Requirements Of UL 2044.



EU Directives covered by this declaration:  
72/9/EC Low Voltage Directives  
89/336/EEC Electromagnetic Compatibility Directive

This installation should be made by a qualified service person and conform to all local codes.

**EXTREME CCTV™** will not be responsible for injuries or damages resulting from the improper installation or use of any camera sold by **EXTREME CCTV™**, their agents, distributors or dealers.

# INDEX – EX44

	<u>Page</u>
Description.....	1
Unpacking.....	2
Parts List.....	2
Items Required for Installation.....	2
Initial Preparations.....	3
Guidelines.....	3
Section 1. Dome Removal.....	4
Section 2. Input Power Connections.....	6
Section 3. Mounting - Camera Base.....	8
Section 4. Directional Adjustment.....	13
Section 5. Dome Re-Assembly.....	17
Section 6. Troubleshooting Guide.....	19
Section 7. Template – Mounting Holes.....	22
Section 8. General Specifications.....	24

## **DESCRIPTION**

The **EX44** is a hardened vandal-tough dome with two fixed cameras inside. Great for urban surveillance where there is need to see in multiple directions, each CCD sensor in the EX44 has can be adjusted for pan/tilt.

An aluminum housing, CNC-machined from a billet, with an impact resistant polycarbonate dome and locking retaining ring, make it extremely rugged and weather-tight.

A voltage regulator circuit automatically allows for *12V dc* or *24V ac* operation without any wiring changes. Its wider voltage range also provides protection from voltage surge, transient spikes, and reverse voltage.

Contact Extreme CCTV™ for information.

- [sales@ExtremeCCTV.com](mailto:sales@ExtremeCCTV.com)
- Tel: 1-888-409-2288 (Toll free NA)

**See the Light. Get the Picture.™**

## **UNPACKING**

Care should be taken when unpacking the shipped unit. Check the parts list and confirm all items have been located. Inspect the equipment thoroughly to ensure nothing was damaged in transit.

Contact Extreme CCTV if a problem is noted.

- [quality@ExtremeCCTV.com](mailto:quality@ExtremeCCTV.com)
- Tel: 1-604-420-7711 or

see the rear of the booklet for contact numbers.

## **PARTS LIST (items supplied with unit)**

- EX44 camera assembly
- Installation Instructions booklet
- Plastic bag containing an Allen key and one ½ NPT plug (wrapped with Teflon sealing tape)

## **ITEMS REQUIRED FOR INSTALLATION**

(not supplied with unit)

- Philips screwdriver
- Small slotted screwdriver
- Silicone sealant and Teflon sealing tape.
- Mounting screws, etc.

## **INITIAL PREPARATIONS**

- Determine the operating voltage at the installation site. The camera's Voltage Regulator Board accepts either 12V dc or 24V ac input. See *Section 2, Input Power Connections*.
- Determine the optimum location for the camera. *Section 3, Mounting-Camera Base*.
- All cameras have been tested prior to shipment. After the wiring has been reconnected, it is advisable to check the camera's operation before installation.
- *ESD protection* – Cameras and circuit boards are sensitive electronic components. It is recommended to wear a ground strap to ground any static charge. (Alternative: touch a grounded metal plate for at least a minute before proceeding with any disassembly)

## **GUIDELINES**

The installation of the EX44 camera is explained in Sections 1 to 5 listed below. It is important that these steps are followed in sequence:

1. Dome Removal
2. Input Power Connections
3. Mounting - Camera Base
4. Directional Adjustment
5. Dome Re-Assembly

## 1. DOME REMOVAL

The camera's dome and its retaining ring must be removed prior to mounting the camera. The set-screws in the retaining ring are not tightened in the factory and protrude by 1/8" (3mm) in order for the ring to be rotated.

Refer to **Figure 1 - 1** on page 5.

Step 1.1 - Place the camera on a flat surface.

Step 1.2 - Press firmly on the dome with one hand and rotate the retaining ring in a counter-clockwise direction with the other hand. Push against the protruding three set-screws with the fingers to rotate the ring. Do not use a screwdriver or other metal device.

Step 1.3 - Remove the dome and the retaining ring. Set them aside.

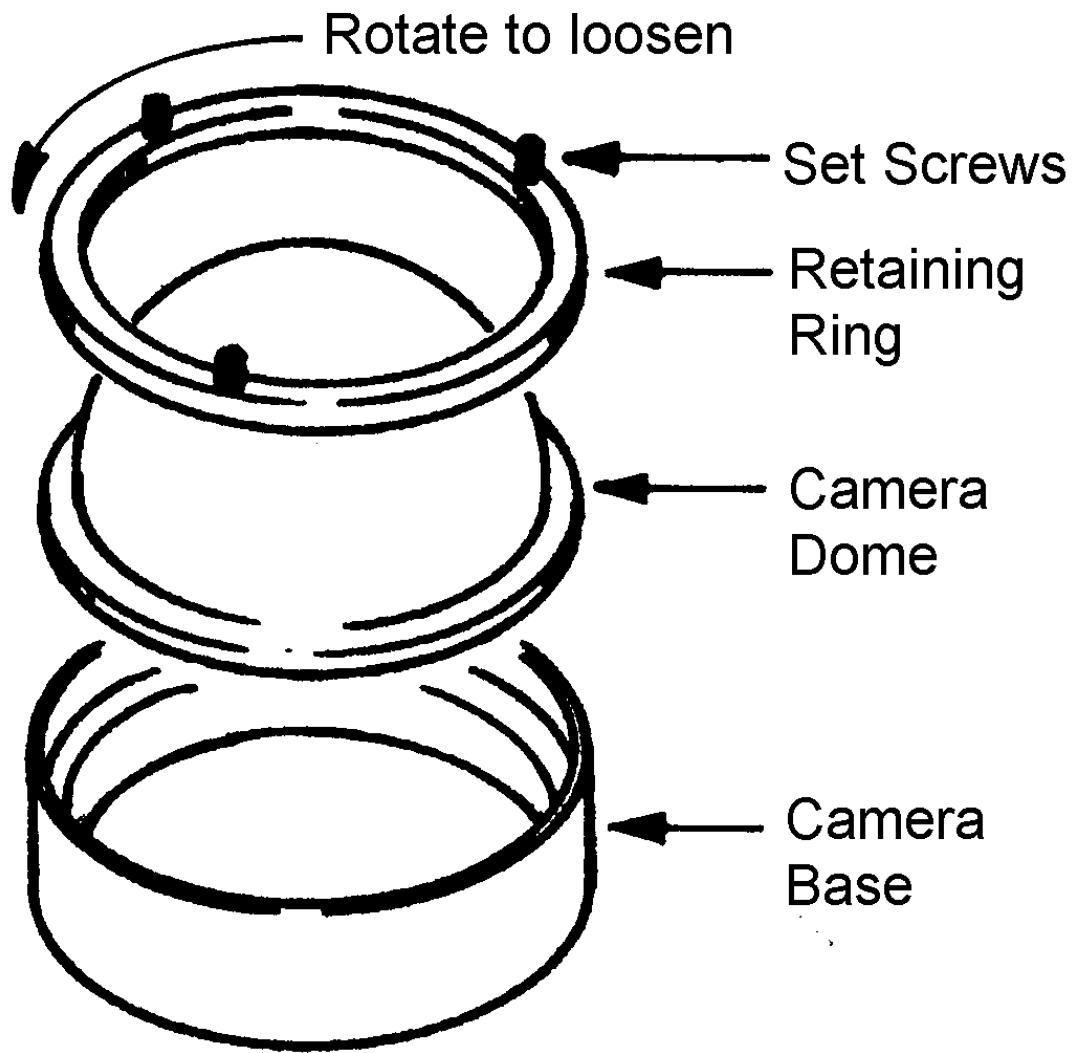

***FIGURE 1 – 1***  
***Dome Removal***

## 2. INPUT POWER CONNECTIONS

**ATTENTION:** External Video Cable Systems Must Be Properly Grounded In Accordance With The National Electrical Code, ANSI/NFPA 70.

The camera unit is pre-connected with an electrically isolated power board for 24V ac or 12V dc operation with no wiring change or wiring polarity. See **Figure 2 - 1** for wiring details. Note: Input voltage is 10.5VDC to 40VDC for DC input. The AC input range is 12VAC to 28VAC.

NOTE: Section 3 explains the camera's mounting procedure.

It would be advantageous to the installer if the power and video wires could be routed through either the side or bottom holes at this time, whichever is applicable. In this way, the wires need only to be removed from the terminal block once.

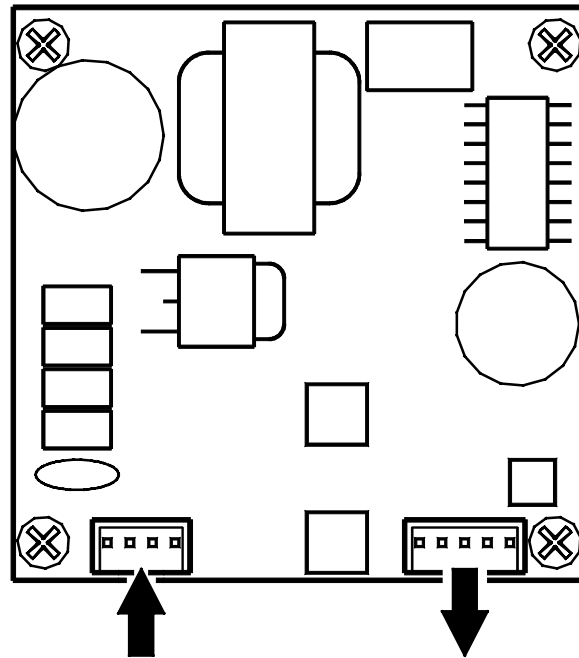

Power  
IN  
from  
supply

Power  
OUT  
to  
camera

**FIGURE 2 - 1**  
**12VDC or 24VAC**  
***Electrically Isolated Power Board***

### 3. MOUNTING - CAMERA BASE

Select a suitable location that is protected from accidental damage, tampering, and environmental conditions exceeding the camera's specifications. The surface should be relatively flat.

*Caution: The selected mounting location should not place the camera in a situation where its environmental specifications could be exceeded. See page 24.*

*Caution: Ensure the selected location is protected from falling objects, accidental contact with moving objects, and unintentional interference from personnel. Follow all applicable building codes.*



The following installation guidelines must be followed:

- Locate the camera such that it cannot be easily interfered with, either intentionally or accidentally.

- Select a mounting surface capable of supporting the combined weight of the camera and mounting hardware under all expected conditions of vibration and temperature.
- Secure all cabling.
- Installations on drywall must use #8 screws and #8 drywall nylon plugs or a superior connection.

The mounting holes are configured for a single-gang electrical box or a round ceiling electrical box. The camera is pre-set for ceiling mount at the factory. See page 22 for the mounting template. The housing can also be mounted to any flat surface.

Step 3.1 - Based on the selected mounting location, determine if the video and the input power wires should enter the housing through either the side or the bottom. For ease of re-assembly, this step should be performed in conjunction with Section 2, Input Power Connections.

- Step 3.2 - Disconnect the wires from the terminal blocks on the Voltage Regulator Board (VRB).
- Step 3.3 - For **side wiring** entry, feed the power and video wires through the side hole and connect them to the terminal blocks per **Figure 3-1** on page 11. Note: The side connector or gland is not supplied. Seal the wiring conduit with silicone to prevent moisture penetration.
- Step 3.4 - For **bottom wiring** entry, feed the wires through the hole in the base and connect them to the terminal blocks. See **Figure 3-2** on page 12. Close the side hole with the ½" NPT plug. Wrap the treads with 1½ turns of Teflon tape if required.
- Step 3.5 - Mount the camera base. A mounting hole template has been provided on page 22 for this procedure.
- Step 3.6 - Seal all holes in the neoprene pad and around the ½" NPT plug with

silicone to prevent moisture penetration.

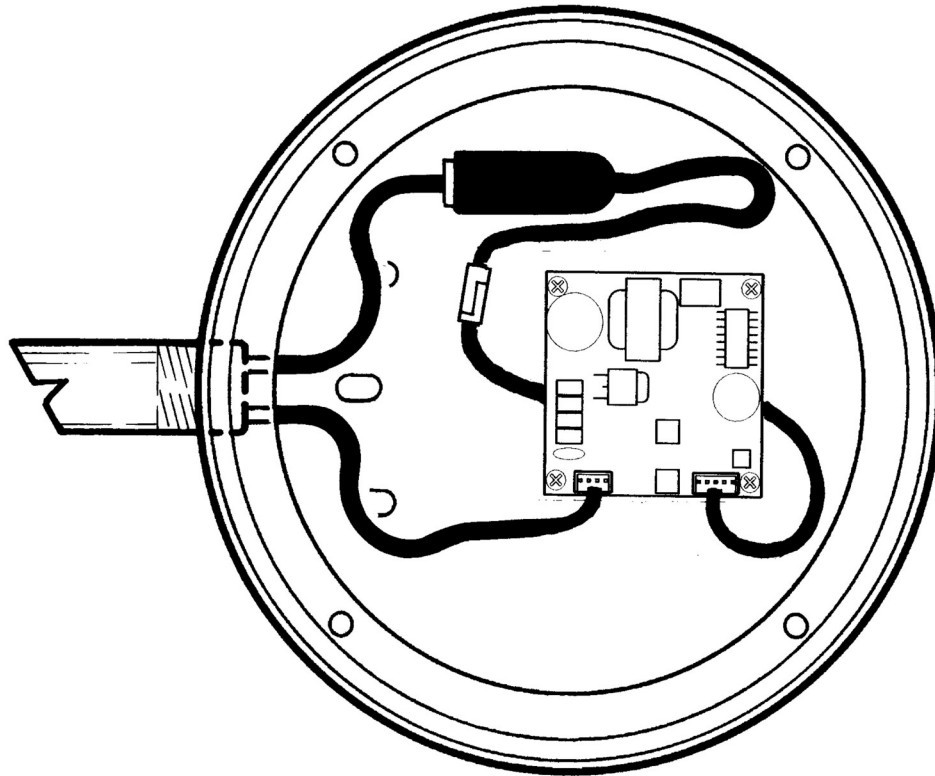

Feed all wires through the 1/2" NPT hole and connect them to their appropriate terminal blocks. Seal the wiring conduit with silicone to prevent moisture penetration

**FIGURE 3 - 1**  
***Side Entry Wiring Connections***

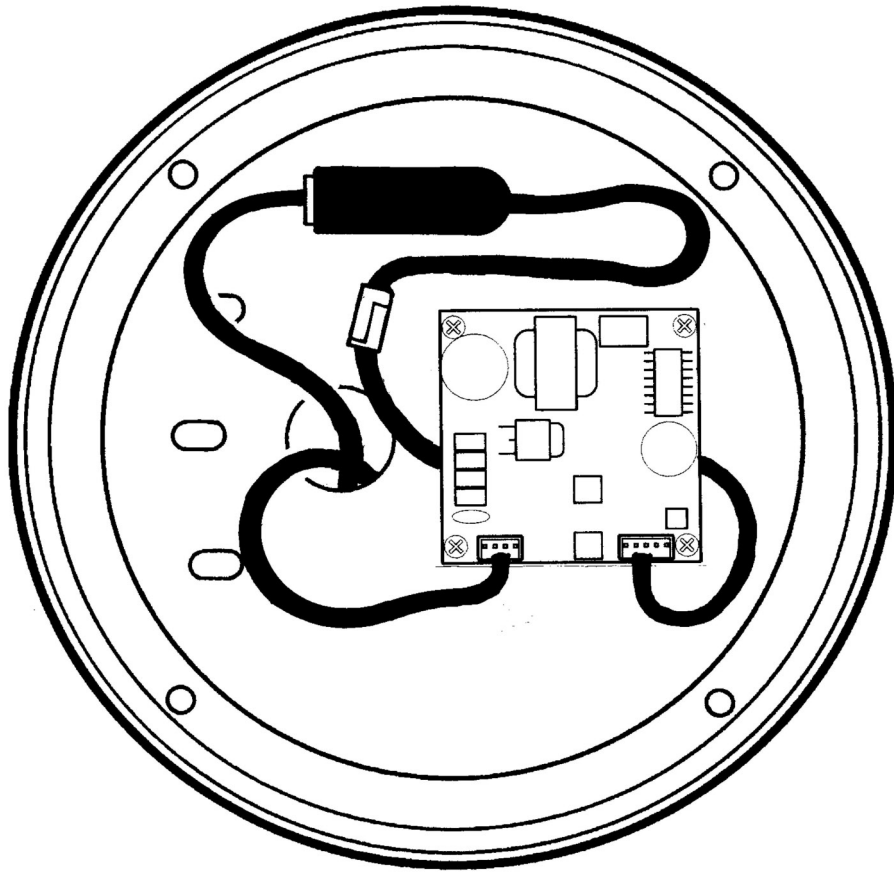

Make sure the wires are not crimped or chafed when feeding them through the bottom hole. Close the side entry hole with the ½" NPT plug. Wrap the plug thread with 1½ turns of Teflon tape before insertion if required.

**FIGURE 3 - 2**  
***Bottom Entry Wiring Connections***

## 4. DIRECTIONAL ADJUSTMENT

For optimum picture quality the camera lens must be as close as possible to the dome's inside face, without touching. However, the foam ring around the lens should be adjusted to seal against the dome, minimizing any side light interference, but without obstructing the field of view.

The lens and inside dome clearance adjustment can be achieved through a combination of sliding mount arrangements.

*For example:* if the lens touches the dome, slide the mount away from the dome.

The installer must determine whether the lens needs to be adjusted once the camera's viewing angle has been finalized.

The camera / lens viewing direction can be adjusted by the rotating the camera mounts. As shipped, the view is set for ceiling mount.

**Note:**

*Gasket Back Cover* - Some products have a paper backing on the gasket. Please remove it before installation.

*Mounting* - It is recommended that the camera be mounted to a flat non-porous surface for best results. The mounting holes and the area around the mounting screws should be sealed with silicone to prevent water or moisture from entering into the unit.

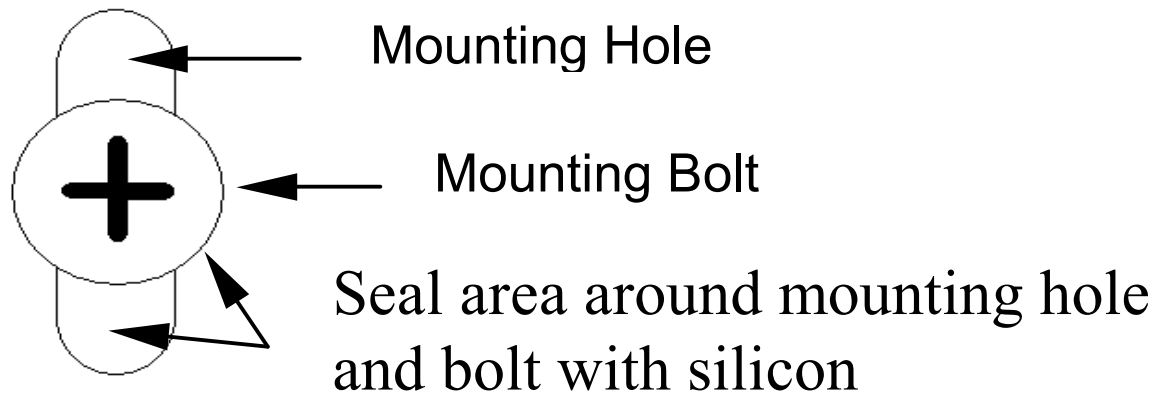

*Conduits and Connectors* - The conduits and connectors connecting to the housing should be sealed with silicone to prevent water and moisture from entering into the unit.

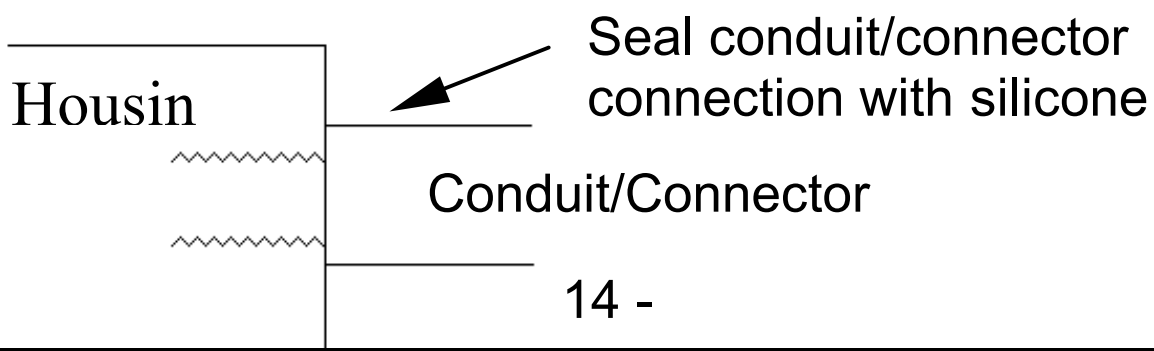

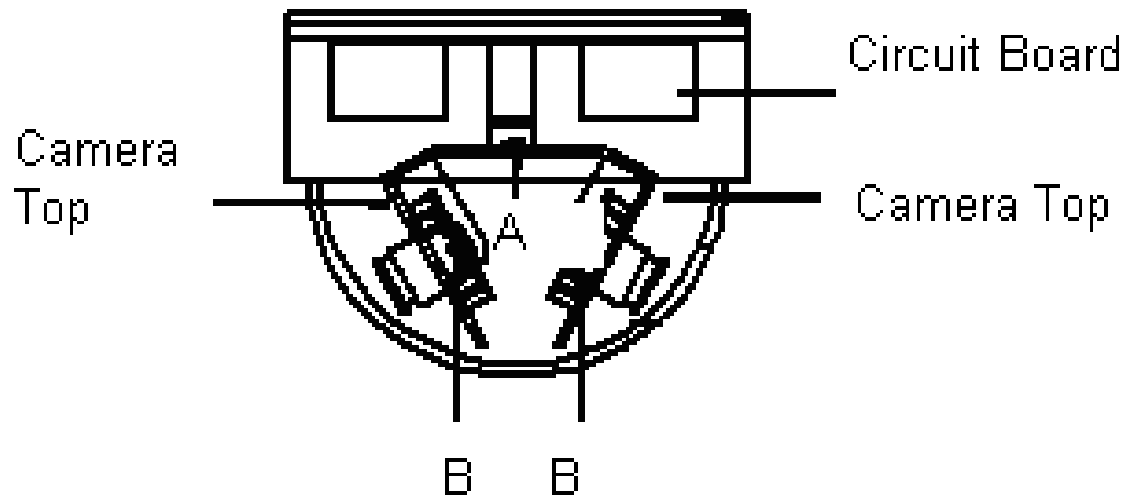

***FIGURE 4 - 1***  
***Camera / Lens Directional Alignment***

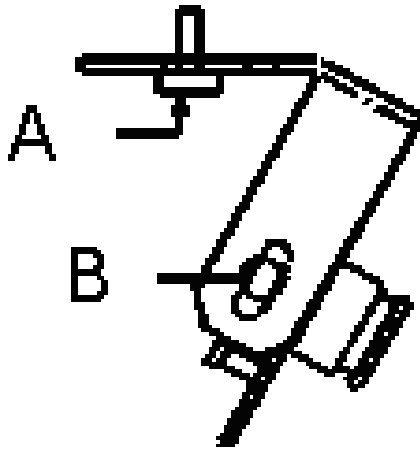

**FIGURE 4 - 2**  
**Camera - Angular Viewing Position**

Step 4.1 - Loosed the bolt at point A to rotate the camera unit. Rotate the two camera mounts to the desired viewing direction. Then tighten the bolt.

Refer to **Figure 4-2**.

Step 4.2 - There are two mounting bolts (B) on the sides of the camera mount. Loosen them to adjust/tilt the view up or down. Tighten the bolts once the correct view is achieved.

Refer to **Figure 4-2**.

## 5. DOME RE-ASSEMBLY

Make sure all wires are properly connected and tightened into the terminal blocks, all holes are sealed against moisture penetration, and all mounting screws are tight.

Step 5.1 - Check that the large “O” ring gasket in the camera base has not been dislodged or distorted.

Step 5.2 - Gently press the camera dome in place. Move the retaining ring over the dome.

Step 5.3 - Use the protruding set-screws in the retaining ring to carefully rotate the ring clockwise until it is slightly snug, but not so tight that the ring cannot rotate further.

Step 5.4 - Press firmly on the dome and rotate the retaining ring until one of the set-screws aligns with the adhesive dot on the side of the dome. Tighten all set-screws with the Allen key (supplied). Refer to **Figure 5-1** on page 18.

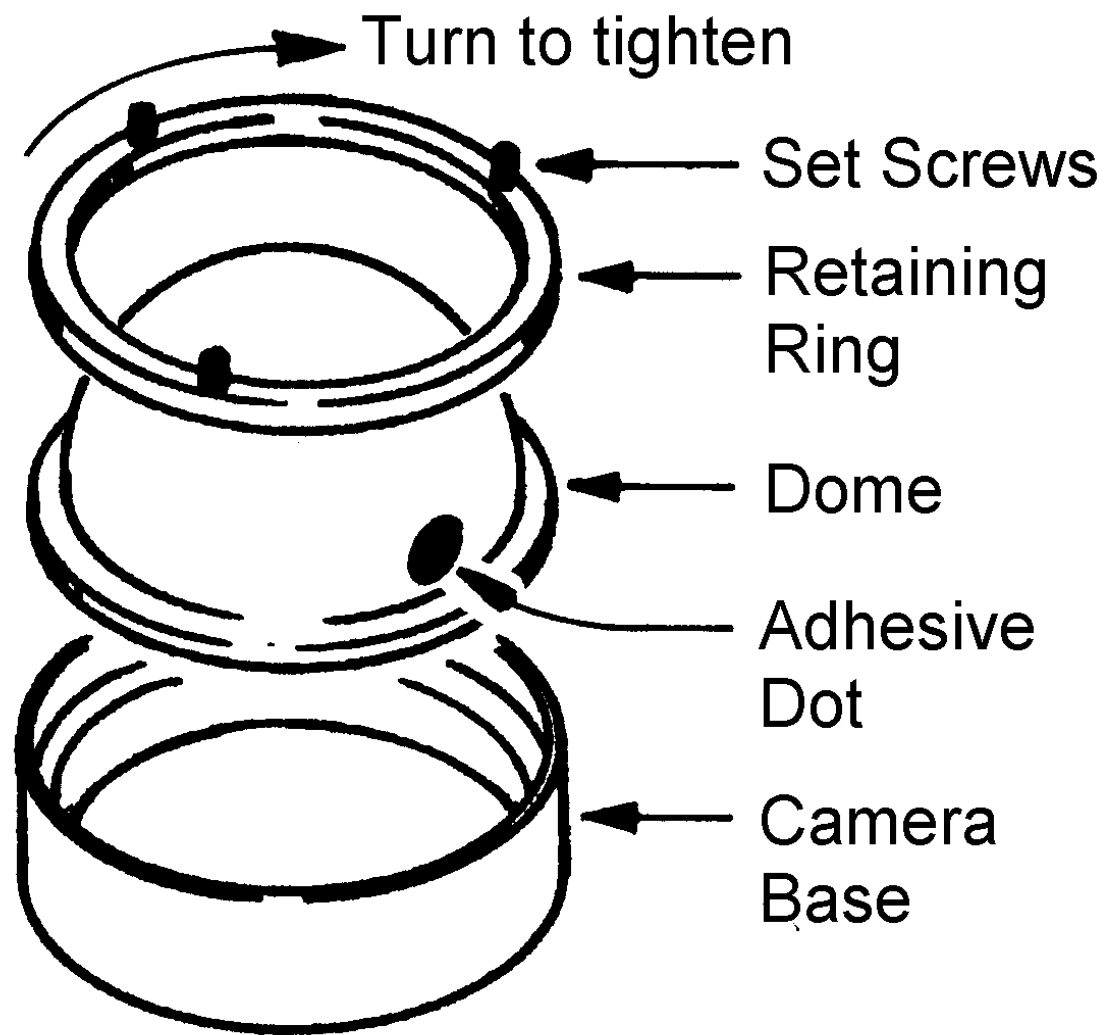

**FIGURE 5 - 1**  
**Dome Re - Assembly**

## 6. TROUBLESHOOTING GUIDE

<i>PROBLEM</i>	<i>POSSIBLE CAUSE</i>	<i>LIKELY SOLUTION</i>
<b>No Video</b>	<p>1. <u>Power Supply:</u> -Connections....</p> <p>-Voltage Range...</p> <p>2. <u>Video Connections:</u></p>	<p>Check input power connections at the cable leads. Check for loose wires.</p> <p>If connected to DC, check input voltage range of 10.5 – 40 V.</p> <p>If connected to AC, check input voltage range of 12 – 28 V.</p> <p>Measure the voltage at the circuit board's Input Power Connector.</p> <p>Determine if wiring polarity at "Video Connector" terminal block is correct. Check BNC cable.</p>

<p><b>No Video (cont'd.)</b></p>	<p>2. Video Connections: (cont'd.)</p>	<p>If still no video, connect the camera directly to the monitor. Check the video signal. If okay, the problem is with the interconnections. If still no video, contact Extreme CCTV (see back cover for contact details).</p>
<hr/> <p><b>Poor Picture Quality</b></p> <p>Snowy Image</p>	<hr/> <p>Poor Video Signal</p> <p>Noisy Power Supply</p>	<hr/> <p>Ensure video cable is correctly matched and terminated with 75 ohms at each end. Make sure video cables are similar types.</p> <p>Check connections. Relocate or replace power supply.</p>

<p>Horizontal Scan Lines, Rolling Up or Down.</p>	<p>Ground Looping on 24V ac.</p>	<p>Check the coax cable shield is not touching ground, e.g. at couplings.</p>
---	----------------------------------	---

## 7. TEMPLATE – MOUNTING HOLES

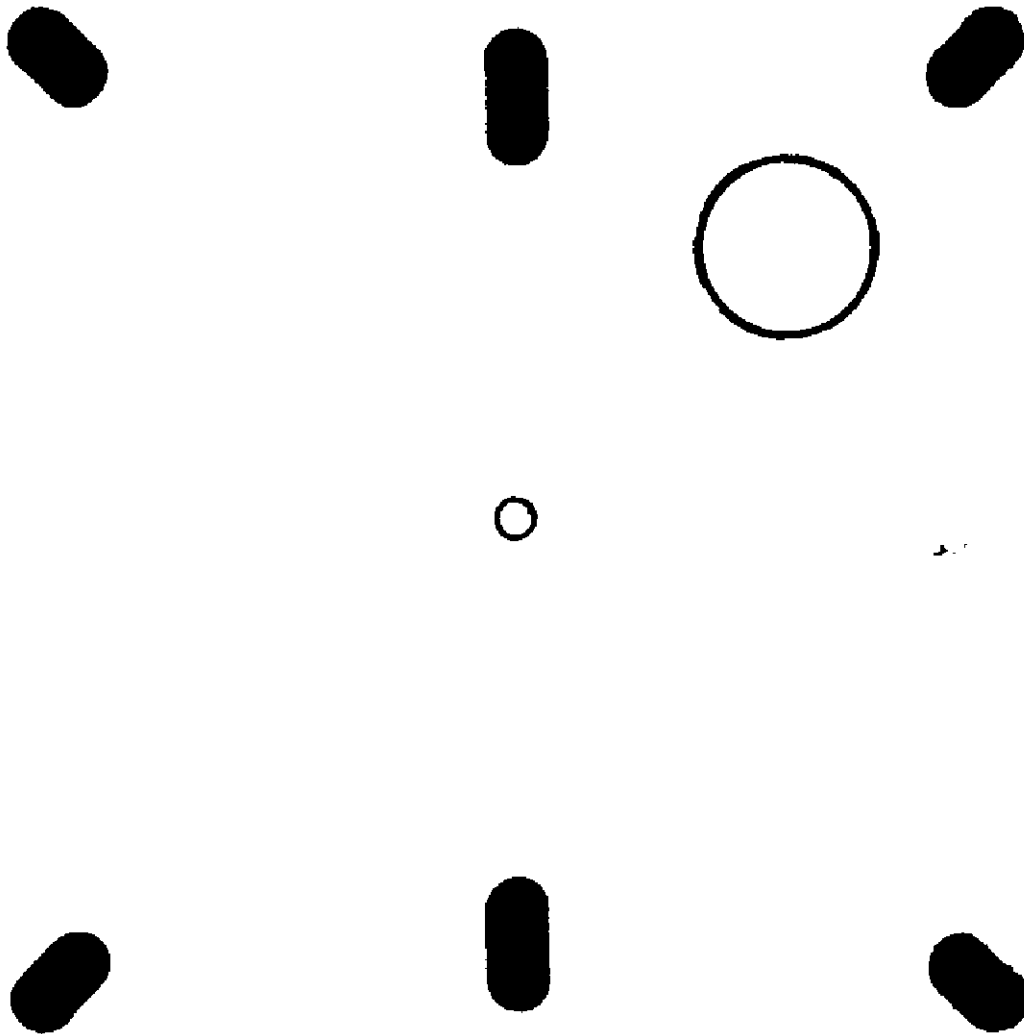

***FIGURE 8 - 1***  
***Base Mounting Holes ( Scale = 1:1 )***



## 8. GENERAL SPECIFICATIONS

TV System ..... Color – NTSC (PAL optional)  
Monochrome – EIA (CCIR optional)

Video Signal Output..... 1 V p-p, 75 Ohm

Operational Range..... -50°C to +60°C  
(-58°F to 140°F)

Humidity Range ..... Up to 85% (relative)

Power Supply..... 12V dc or 24V ac  
(60Hz), 10W Max.

Dome ..... Polycarbonate  
Base & Retaining Ring ..... CNC Aluminum  
Anodized

Dimensions ..... 4.6" (118mm) dia.  
3.68" (93.5 mm) ht.

Weight..... 1.0 lbs. (454g)

*Subject To Change Without Notice.*



# Extreme CCTV®

## SURVEILLANCE SYSTEMS

<b>Canada</b>	3021 Underhill Avenue, Burnaby, BC V5A 3C2
<b>USA</b>	3873 - C Airport Way, PO Box 9754, Bellingham, WA 98227
<b>tel</b>	1-888-409-2288 (toll free) 1-604-420-7711
<b>fax</b>	1-604-420-3300
<b>e-mail</b>	tech@ExtremeCCTV.com
<b>Web</b>	www.ExtremeCCTV.com
<b>Europe</b>	Colbourne Cres. Cramlington, Northumberland United Kingdom, NE23 1WB
<b>Tel</b>	+44 (0) 1670.730.187
<b>Fax</b>	+44 (0) 1670.730.188

**Dealer / Distributor:**