



Videolarm®



www.videolarm.com

SSY7 + SSY75

Sunshield

Installation and Operation Instructions for the following models:

SSY7 Sunshield for RH7 or Fusion Dome FD7 housing.

SSY75 Sunshield for RH75 or Fusion Dome FD75 housing

Before attempting to connect or operate this product,
please read these instructions completely.

81-IN5365R0

IMPORTANT SAFEGUARDS

- 1 Read Instructions - All the safety and operating instructions should be read before the unit is operated.
- 2 Retain Instructions - The safety and operating instructions should be retained for future reference.
- 3 Heed Warnings - All warnings on the unit and in the operating instructions should be adhered to.
- 4 Follow Instructions - All operating and user instructions should be followed.
- 5 Electrical Connections - Only a qualified electrician should make electrical connections..
- 6 Attachments - Do not use attachments not recommended by the product manufacturer as they may cause hazards.
- 7 Cable Runs - All cable runs must be within permissible distance
- 8 Mounting - This unit must be properly and securely mounted to a supporting structure capable of sustaining the weight of the unit.

Accordingly:

- a. The installation should be made by a qualified installer.
- b. The installation should be in compliance with local codes.
- c. Care should be exercised to select suitable hardware to install the unit, taking into account both the composition of the mounting surface and the weight of the unit.

Be sure to periodically examine the unit and the supporting structure to make sure that the integrity of the installation is intact. Failure to comply with the foregoing could result in the unit separating from the support structure and falling, with resultant damages or injury to anyone or anything struck by the falling unit.

UNPACKING

Unpack carefully. Electronic components can be damaged if improperly handled or dropped. If an item appears to have been damaged in shipment, replace it properly in its carton and notify the shipper.

Be sure to save:

- 1 The shipping carton and packaging material. They are the safest material in which to make future shipments of the equipment.
- 2 These Installation and Operating Instructions.

SERVICE

If technical support or service is needed, contact Sony at the following number:

TECHNICAL SUPPORT
8:15AM to 7:30PM (Eastern Time)
1-800-883-6817

SAFETY PRECAUTIONS



The lightning flash with an arrowhead symbol, within an equilateral triangle, is intended to alert the user to the presence of non-insulated "dangerous voltage" within the product's enclosure that may be of sufficient magnitude to constitute a risk of electric shock to persons.

Spanish

Este símbolo se piensa para alertar al usuario a la presencia del "voltaje peligroso no aislado" dentro del recinto de los productos que puede ser un riesgo del choque eléctrico.

French

Ce symbole est prévu pour alerter l'utilisateur à la présence "de la tension dangereuse" non isolée dans la clôture de produits qui peut être un risque de choc électrique.

German

Dieses Symbol soll den Benutzer zum Vorhandensein der nicht isolierter "Gefährdungsspannung" innerhalb der Produkteinschließung alarmieren, die eine Gefahr des elektrischen Schlages sein kann.

Portuguese

Este símbolo é pretendido alertar o usuário à presença "da tensão perigosa não isolada" dentro do cerco dos produtos que pode ser um risco de choque elétrico.

Italian

Questo simbolo è inteso per avvertire l'utente alla presenza "di tensione pericolosa" non isolata all'interno della recinzione dei prodotti che può essere un rischio di scossa elettrica.



The exclamation point within an equilateral triangle is intended to alert the user to presence of important operating and maintenance (servicing) instructions in the literature accompanying the appliance.

Spanish

Este símbolo del punto del exclamation se piensa para alertar al usuario a la presencia de instrucciones importantes en la literatura que acompaña la aplicación.

French

Ce symbole de point d'exclamation est prévu pour alerter l'utilisateur à la présence des instructions importantes dans la littérature accompagnant l'appareil.

German

Dieses Ausruf Punktsymbol soll den Benutzer zum Vorhandensein der wichtigen Anweisungen in der Literatur alarmieren, die das Gerät begleitet.

Portuguese

Este símbolo do ponto do exclamation é pretendido alertar o usuário à presença de instruções importantes na literatura que acompanha o dispositivo.

Italian

Questo simbolo del punto del exclamation è inteso per avvertire l'utente alla presenza delle istruzioni importanti nella letteratura che accompagna l'apparecchio.



LIMITED WARRANTY FOR VIDEOLARM INC. PRODUCTS

VIDEOLARM INC. warrants this Product to be free from defects in material or workmanship, as follows:

PRODUCT CATEGORY	PARTS	LABOR
All Enclosures and Electronics	Three (3) Years	Three (3) Years
Pan/Tilts	Three (3) Years **6 months if used in autoscan	Three (3) Years **6 months if used in autoscan
Poles/PoleEvators	Three (3) Years	Three (3) Years
Warrior/Q-View/I.R. Illuminators	Five (5) Years	Five (5) Years
Controllers	Three (3) Years	Three (3) Years
Power Supplies	Three (3) Years	Three (3) Years
Accessory Brackets	Three (3) Years	Three (3) Years

During the labor warranty period, to repair the Product, Purchaser will either return the defective product, freight prepaid, or deliver it to Videolarm Inc. Decatur GA. The Product to be repaired is to be returned in either its original carton or a similar package affording an equal degree of protection with a RMA # (Return Materials Authorization number) displayed on the outer box or packing slip. To obtain a RMA# you must contact our Technical Support Team at 800.554.1124, extension 101. Videolarm will return the repaired Product freight prepaid to Purchaser. Videolarm is not obligated to provide Purchaser with a substitute unit during the warranty period or at any time. After the applicable warranty period, Purchaser must pay all labor and/or parts charges.

The limited warranty stated in these product instructions is subject to all of the following terms and conditions:

1. NOTIFICATION OF CLAIMS: WARRANTY SERVICE: If Purchaser believes that the Product is defective in material or workmanship, then written notice with an explanation of the claim shall be given promptly by Purchaser to Videolarm but all claims for warranty service must be made within the warranty period. If after investigation Videolarm determines that the reported problem was not covered by the warranty, Purchaser shall pay Videolarm for the cost of investigating the problem at its then prevailing per incident billable rate. No repair or replacement of any Product or part thereof shall extend the warranty period as to the entire Product. The specific warranty on the repaired part only shall be in effect for a period of ninety (90) days following the repair or replacement of that part or the remaining period of the Product parts warranty, whichever is greater.

2. EXCLUSIVE REMEDY: ACCEPTANCE: Purchaser's exclusive remedy and Videolarm's sole obligation is to supply (or pay for) all labor necessary to repair any Product found to be defective within the warranty period and to supply, at no extra charge, new or rebuilt replacements for defective parts.

3. EXCEPTIONS TO LIMITED WARRANTY: Videolarm shall have no liability or obligation to Purchaser with respect to any Product requiring service during the warranty period which is subjected to any of the following: abuse, improper use: negligence, accident, lightning damage or other acts of God (i.e., hurricanes, earthquakes), modification, failure of the end-user to follow the directions outlined in the product instructions, failure of the end-user to follow the maintenance procedures recommended by the International Security Industry Organization, written in product instructions, or recommended in the service manual for the Product. Furthermore, Videolarm shall have no liability where a schedule is specified for regular replacement or maintenance or cleaning of certain parts (based on usage) and the end-user has failed to follow such schedule; attempted repair by non-qualified personnel; operation of the Product outside of the published environmental and electrical parameters, or if such Product's original identification (trademark, serial number) markings have been defaced, altered, or removed. Videolarm excludes from warranty coverage Products sold AS IS and/or WITH ALL FAULTS and excludes used Products which have not been sold by Videolarm to the Purchaser. All software and accompanying documentation furnished with, or as part of the Product is furnished "AS IS" (i.e., without any warranty of any kind), except where expressly provided otherwise in any documentation or license agreement furnished with the Product.

4. PROOF OF PURCHASE: The Purchaser's dated bill of sale must be retained as evidence of the date of purchase and to establish warranty eligibility.

DISCLAIMER OF WARRANTY EXCEPT FOR THE FOREGOING WARRANTIES, VIDEOLARM HEREBY DISCLAIMS AND EXCLUDES ALL OTHER WARRANTIES, EXPRESS OR IMPLIED, INCLUDING, BUT NOT LIMITED TO ANY AND/OR ALL IMPLIED WARRANTIES OF MERCHANTABILITY, FITNESS FOR A PARTICULAR PURPOSE AND/OR ANY WARRANTY WITH REGARD TO ANY CLAIM OF INFRINGEMENT THAT MAY BE PROVIDED IN SECTION 2-312(3) OF THE UNIFORM COMMERCIAL CODE AND/OR IN ANY OTHER COMPARABLE STATE STATUTE. VIDEOLARM HEREBY DISCLAIMS ANY REPRESENTATIONS OR WARRANTY THAT THE PRODUCT IS COMPATIBLE WITH ANY COMBINATION OF NON-VIDEOLARM PRODUCTS OR NON-VIDEOLARM RECOMMENDED PRODUCTS PURCHASER CHOOSES TO CONNECT TO PRODUCT.

LIMITATION OF LIABILITY THE LIABILITY OF VIDEOLARM, IF ANY, AND PURCHASER'S SOLE AND EXCLUSIVE REMEDY FOR DAMAGES FOR ANY CLAIM OF ANY KIND WHATSOEVER, REGARDLESS OF THE LEGAL THEORY AND WHETHER ARISING IN TORT OR CONTRACT, SHALL NOT BE GREATER THAN THE ACTUAL PURCHASE PRICE OF

1



Remove the dome and trim ring assembly from the housing.

- Quite la bóveda y ajuste el montaje del anillo de la cubierta.
- Enlevez le dôme et équilibrez l'anneau du logement.
- Entfernen Sie die Haube und trimmen Sie Ring vom Gehäuse.
- Remova a abóbada e apare o conjunto do anel da carcaça.
- Rimuova la cupola ed assetti il complessivo dell'anello dall'alloggiamento.

2

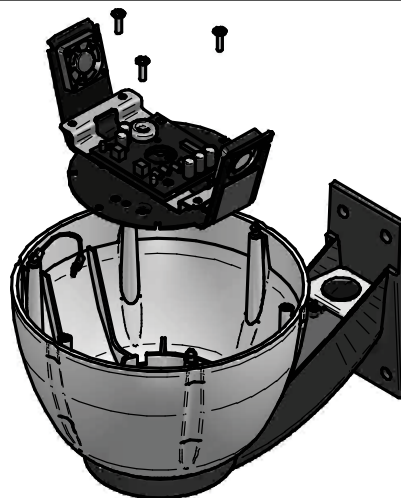

To remove bracket assembly; unbolt the (3) number 10 screws and washers.

- Para quitar el montaje de soporte; desemperne (3) los tornillos y las arandelas del número 10.
- Pour enlever le support ; dévrouillez (3) les vis et les rondelles du numéro 10.
- Haltewinkel entfernen; unbolt die (3) Schrauben und Unterlegscheiben der Nr. 10.
- Para remover o conjunto de suporte; desferrolhe (3) os parafusos e as arruelas do número 10.
- Per rimuovere il complessivo staffa; sbulloni (3) le viti e le rondelle di numero 10.

3

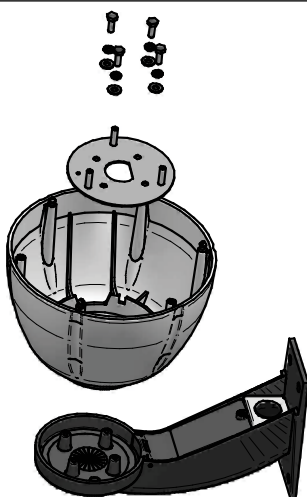

To remove upper support plate, unbolt (4) 1/4 x 20 hex head bolt.

- Para quitar la placa de ayuda superior, desemperne (4) el perno principal de 1/4 x 20 tuercas hexagonales.
- Pour enlever la plaque de maintien supérieure, dévrouillez (4) le boulon principal de 1/4 x 20 sortilèges.
- Um obere Halteplatte zu entfernen, unbolt (4) den Hauptschraubbolzen mit 1/4 x 20 Hexagonen.
- Para remover a placa de sustentação superior, desferrolhe (4) o parafuso principal de 1/4 x 20 hex.
- Per rimuovere la piastra di sostegno superiore, sbulloni (4) un bullone capo dei 1/4 x 20 di hex.

4

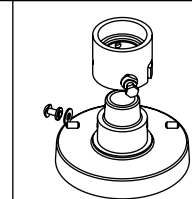

Pendent Coupling

Insert sunshield between wall mount bracket (or pendant coupling). Reinstall enclosure in opposite order.

- Inserte el protector del sol entre el soporte del montaje de la pared (o el acoplador pendiente). Reinstale el recinto en orden opuesta.
- Insérez le bouclier du soleil entre la parenthèse de bâti de mur (ou l'accouplement pendent). Réinstallez la clôture dans l'ordre opposé.
- Setzen Sie Sonneschild zwischen Wandeinfassung Haltewinkel ein (oder hängender Koppelung). Installieren Sie Einschließung im gegenüberliegenden Auftrag wieder.
- Introduza o protetor do sol entre o suporte da montagem da parede (ou o acoplamento pendent). Reinstale o cerco na ordem oposta.
- Inserisca lo schermo del sole fra la staffa del supporto della parete (o l'accoppiamento pendent). Reinstalli la recinzione nell'ordine opposto.