



The QPT-90IC is part of the product line of “Smart” positioning systems which are significantly more capable than basic pan and tilt units. These enhanced designs embed powerful microprocessor controllers, which can be effortlessly programmed to adjust limits of motion, speed, and Azimuth/Elevation position.

Embedded functions include preset repeatable positions, tours, jog or direct manual entry with 12 bit absolute position feedback, convenient edit and adjustable dwell times. The “Smart” concept eliminates the need for separate interface electronics and is connected to the control station using a cost efficient “single cable feed”. No calibration or homing cycle is required for startup.

RS232/422/485 or optional Ethernet connectivity can be used to control both the pan and tilt functions as well as the instruments and equipment mounted on the positioner. QuickSet “Smart” systems interface with stabilization and tracking systems, on-screen displays, and system interface programs of various types.

The QPT-90IC includes auto-baud detection, and includes a 6 ft. test cable (custom lengths of cable are available upon request).

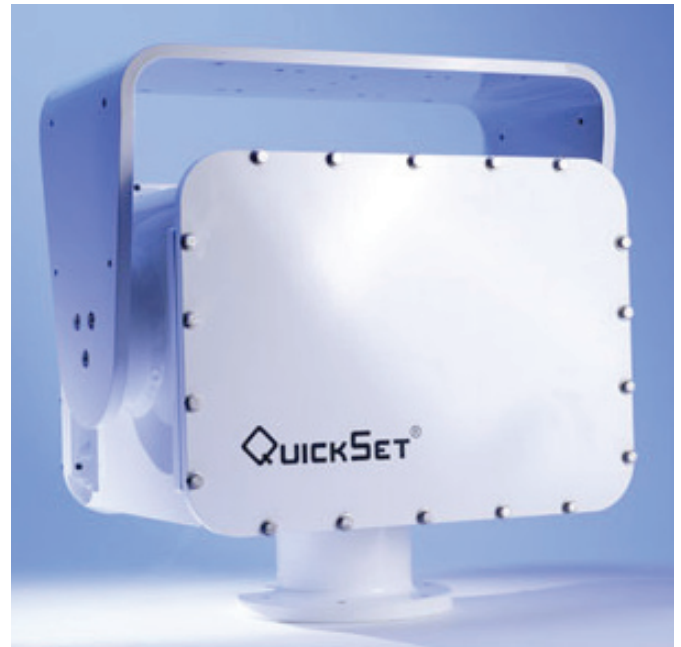

Key Features

- Designed for Heavy Duty Operation and Fixed Operation
- 435° pan rotation, ± 90° tilt motion
- 90 pound (41 kg) load capacity
- Various voltages available for fixed and variable speed models
- All metal gearing
- Aluminum housing with powder coat finish
- Potentiometers (for position feedback) available on certain models
- Stainless steel hardware
- Gasketed to withstand water and dust penetration
- Zero adjustable backlash
- Heater and Stainless Steel Base options

Key Features continued

Voltage:	12 VDC	24 VDC
Load Capacity:	90ft.-lbs. (12 kg-m)	90ft.-lbs. (12 kg-m)
Duty Cycle:	Intermittent	Intermittent
Pan Range:	435° (±217.5°)	435° (±217.5°)
Pan Speed:	.5° - 10° / sec.	.3° - 8° / sec
Pan Torque:	30 ft.-lbs	30 ft.-lbs
Pan Motor Current:	2.0 amp	1.9 amp
Tilt Range:	180° (±90°)	180° (±90°)
Tilt Speed Range:	0.1° - 3°/ sec.	0.1° - 4.5°/ sec.
Tilt Torque:	90 ft.-lbs	90 ft.-lbs
Motor Type:	Permanent Magnet	Permanent Magnet
Connector:	17 pin (mating connector included)	
Weight:	37 lbs (16.8 kg)	
Dimensions:	12.31"H x 12.36"W x 8.87"D (313mmH x 314mmW x 225mmD)	
Drivetrain:	Steel gear & worm, ball & tapered roller bearings, steel chain	
Limit Switches:	Internally adjustable "hard limits", electronically adjustable "soft limits"	
Backlash:	Adjustable to 0	
Repeatability:	0.25°	
Material:	Housing - Aluminum 6061 - T6, External Hardware & Covers - Stainless Steel	
Exterior Color/Finish:	Dupont 326162A, Ford PFWS9 Powder Coated (custom colors/private labeling upon request)	
Environmental Enclosure:	Gasketed & sealed to withstand water & dust penetration	
Heater:	120 volt, 450 watt	
Operating Temperature:	+5°F to +131°F (-15°C to +55°C) (without heater operating) -22°F to +131°F (-30°C to +55°C) (with heater operating)	
Heater:	Standard	
Position Feedback:	Potentiometer	
Set-up commands include:	<p>Electronic limit of motion for both pan and tilt</p> <p>Setting of minimum and maximum speeds</p> <p>Establishing 32 preset locations, including "home position"</p> <p>"Tour" feature allows construction of up to 63 steps of the preset positions continuously with variable dwell times between them. Three tours may be stored in on board memory.</p> <p>Setting normal/reverse mode of movement and position feedback</p> <p>Alignment to local or global coordinates</p> <p>Includes test/operation software (Requires Windows 95, SR2, 98, ME or XP; not compatible with Windows NT or 2000)</p>	
Software includes:	<p>Access to all setup parameters</p> <p>Virtual joystick for jog position</p> <p>Visual analog and digital position indicators, plus destination readouts</p> <p>Visual analog and digital position indicators, plus destination readouts</p> <p>Set up and access of tour feature</p> <p>Diagnostic communication and fault indicators</p> <p>Protocol analyzer</p> <p>Move monitor allows logging of positions acquired</p>	

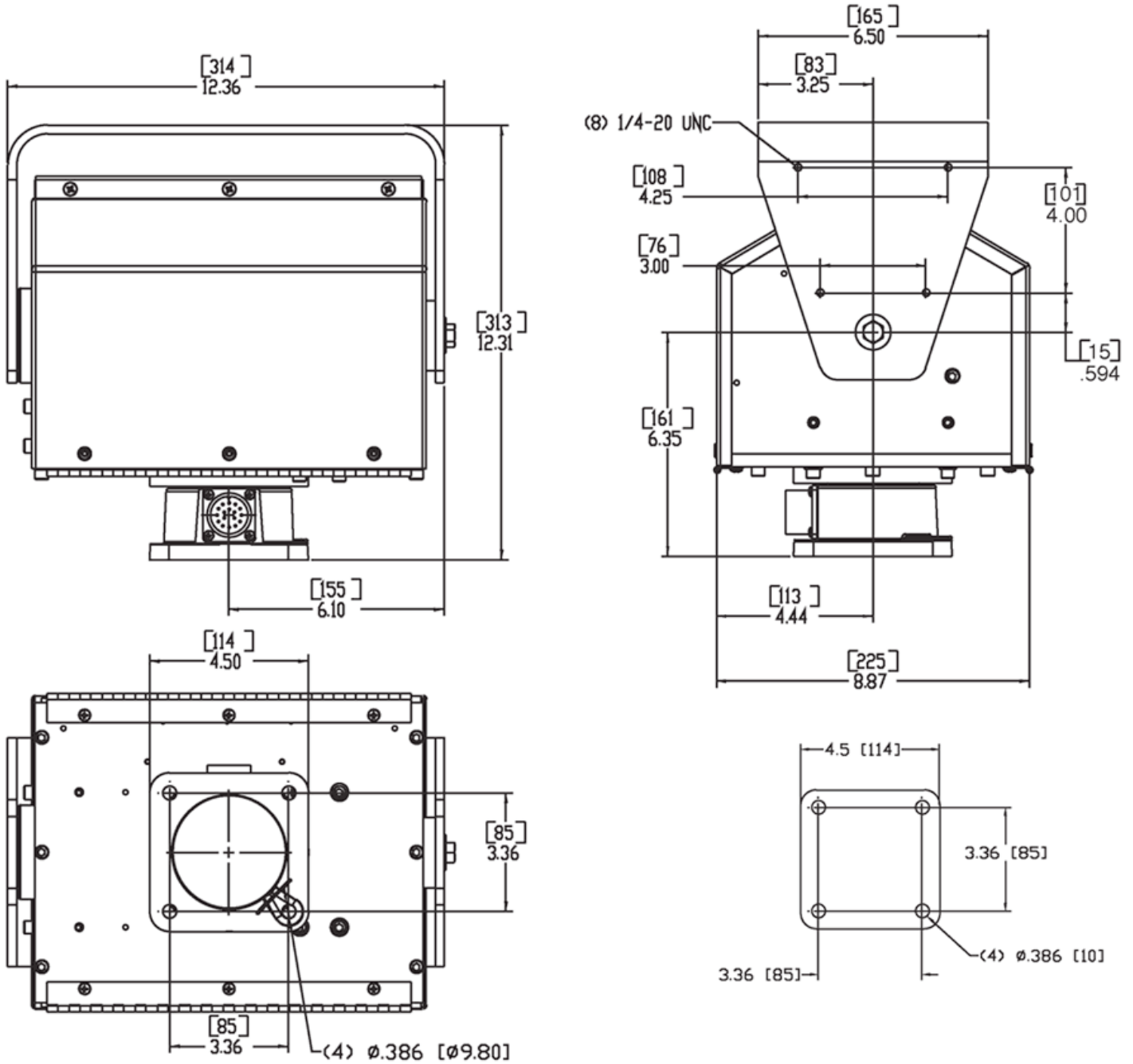

Dimensions are in inches [mm]