

Model Covered:

QPT-130/150 ... 115 VDC variable speed*

* with proper controller

For Severe Duty - OFF ROAD
Electro-Mechanical Pan & Tilt



MODEL	SERIES	DESCRIPTION
7-59510	QPT-130/150	115 VDC; pan $\pm 217.5^\circ$, 8.5°/sec; tilt $\pm 90^\circ$, 3°/sec with pots, stow switch, heater, stainless steel base

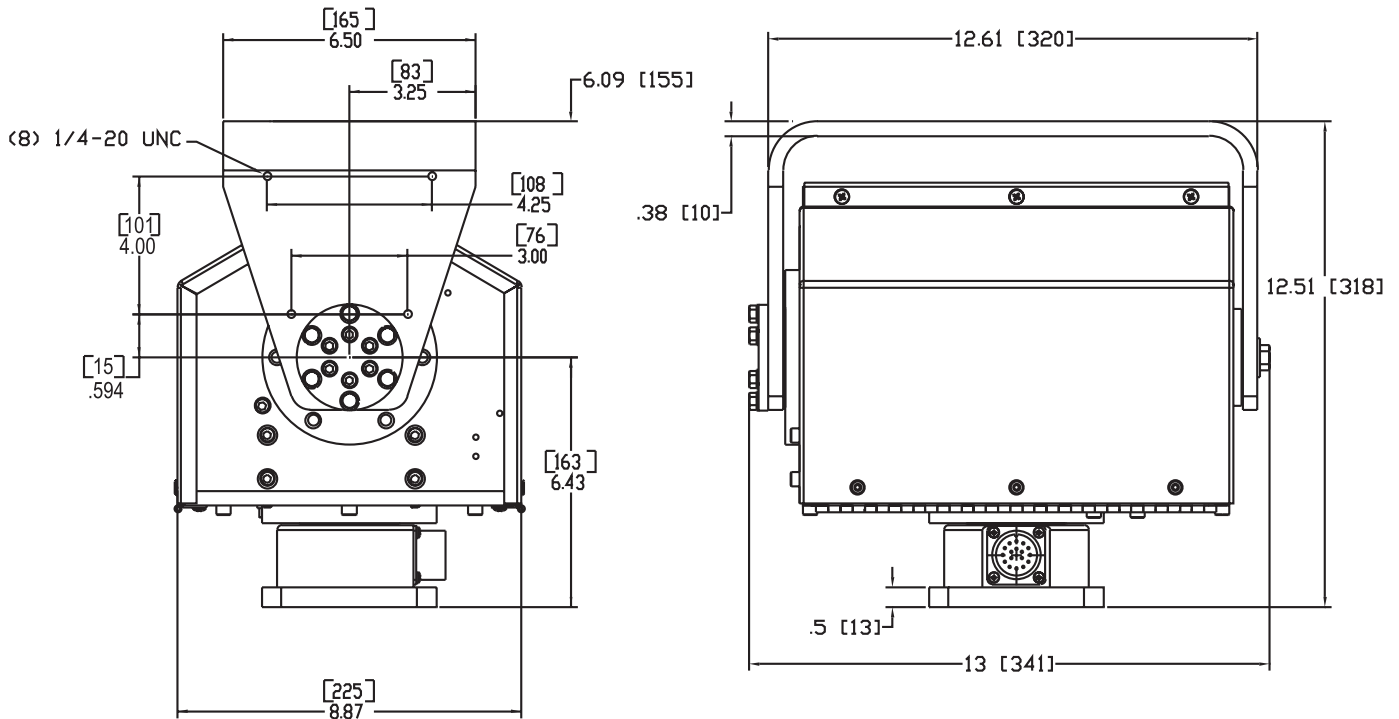

KEY FEATURES:

- Designed for Heavy Duty, Off Road Operation
- 435° pan rotation
- 130 lbs. (59 kg) load capacity mobile operation
- 150 lbs. (68 kg) load capacity fixed installation
- All metal gearing
- Aluminum housing with powder coat finish
- Stainless steel base & hardware
- Heater included
- Potentiometers included

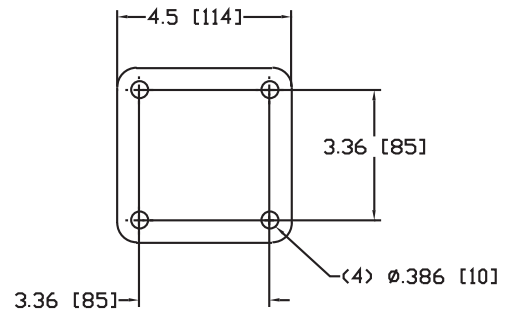

Dimensions are in inches [mm]

For Those Who Demand Durability!

SPECIFICATIONS OF PAN & TILT QPT-130/150

QPT-130/150

Voltage	115VDC
Load Capacity	130 lbs. (59 kg) mobile operation, 150 lbs. (68 kg) fixed installation
Duty Cycle	Intermittent
Pan Range	435° ($\pm 217.5^\circ$)
Pan Speed Range ($\pm 1^\circ$)	.5° - 8.5° / sec.
Pan Torque	50 foot-pounds
Pan Motor Current	0.3 amp
Tilt Range	180° ($\pm 90^\circ$)
Tilt Speed Range ($\pm 1^\circ$)	.1° - 3° / sec.
Tilt Torque	150 foot-pounds
Tilt Motor Current	0.4 amp
Motor Type	Permanent Magnet
Connector	17 pin
Dimensions	12.51"H x 12.61"W x 8.87"D (318mmH x 320mmW x 225mmD)
Weight	44 lbs. (20 kg)
Drivetrain	Steel gear & worm, ball & tapered roller bearings
Limit Switches	Internal, adjustable
Backlash	Adjustable to 0
Accuracy	0.25° with potentiometers
Material	Housing - Aluminum 6061 - T6, Hardware & Base - Stainless Steel
Exterior Color/Finish	Dupont 326162A, Ford PFWS9 Powder Coated (custom colors/private labeling upon request)
Environmental Enclosure	Gasketed & sealed to withstand water & dust penetration
Operating Temperature	+5°F to +131°F (-15°C to +55°C) (without heater operating) -22°F to +131°F (-30°C to +55°C) (with heater operating)

*Specifications may change without notice

TABLE TOP MOUNTING HOLE DIMENSIONS

Dimensions are in inches [mm]

