



PT1250P Pan/Tilt

OUTDOOR, HEAVY DUTY

Product Features

- 120 VAC or 230 VAC Operation
- Optional Preset Positioning Capability
- Heavy Duty, Adjustable Worm-Gear Final Drive
- External Pan and Tilt Limit Adjustment
- Capable of Auto/Random Scan Operation
- Rugged Aluminum Construction
- Indoor/Outdoor Applications
- Maximum Load 100 Pounds (45.4 kg)



The **PT1250P** is a heavy duty pan/tilt easily capable of handling loads up to 100 pounds (45.4 kg). Equipped with high torque AC motors with adjustable worm-gear final drives, this pan/tilt ensures long operational life as well as drift-free operation.

The **PT1250P** is capable of auto/random scan operation when used with our solid-state auto/random scan joystick control. No additional conductors, micro switches, or relays are required for auto/random scan operation.

The **PT1250P** is manufactured from cast and plate aluminum with all internal parts corrosion-protected steel or aluminum. Limit stops are externally adjustable for ease of installation.

The **PT1250P** is recommended for use with our EH5700 Series environmental enclosures.

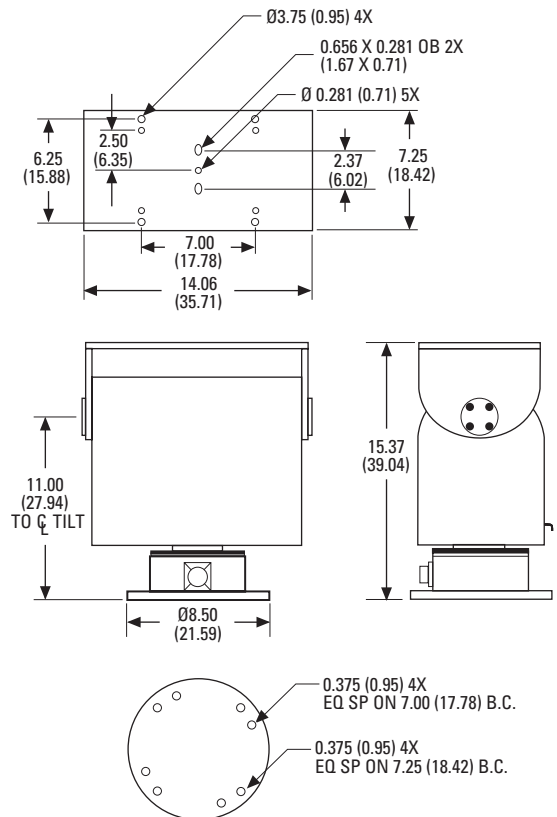

NOTE: VALUES IN PARENTHESES ARE CENTIMETERS; ALL OTHERS ARE INCHES.



TECHNICAL SPECIFICATIONS

MODELS

PT1250P	Heavy duty pan/tilt, 120 VAC
PT1250P/220	Heavy duty pan/tilt, 230 VAC
PT1250P/PP	Same as PT1250P except has preset positioning option. Requires preset control

ELECTRICAL

		PT1250P	PT1250P/220
Input Voltage		120 VAC, 50/60 Hz	230 VAC, 50 Hz
Power Requirements			
	(Running)	Pan 0.48A (57.5 VA) Tilt 0.48A (57.5 VA)	0.19A (43.7 VA) 0.27A (62.1 VA)
	(Starting)	Pan 0.60A (72.5 VA) Tilt 0.60A (72.5 VA)	0.19A (43.7 VA) 0.27A (62.1 VA)
Connectors		AMP CPC type (mate supplied)	
Motors		Two-phase induction type, instantaneous reversing	
Limit Switches		5A each (pan and tilt); external adjustment	
Conductor Requirements		6 or 7, unshielded (functions: left, right, up, down, motor common, safety ground). No additional conductors for auto scan when used with solid-state control. PP option requires additional 4 conductors	

Maximum Operating Distances

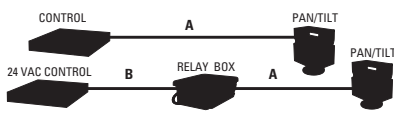

	Cable Size	Maximum Distance	
		A	B
PT1250P 6 Conductors	20 AWG (0.5 mm ²)	489 ft (149 m)	5,800 ft (1,767 m)
	18 AWG (1.0 mm ²)	778 ft (237 m)	8,250 ft (2,515 m)
	16 AWG (1.5 mm ²)	1,235 ft (376 m)	13,000 ft (3,962 m)
7* Conductors	20 AWG (0.5 mm ²)	978 ft (298 m)	
	18 AWG (1.0 mm ²)	1,556 ft (474 m)	
	16 AWG (1.5 mm ²)	2,470 ft (752 m)	
PT1250P/220 6 Conductors	20 AWG (0.5 mm ²)	2,463 ft (750 m)	
	18 AWG (1.0 mm ²)	3,918 ft (1,194 m)	
	16 AWG (1.5 mm ²)	6,218 ft (1,895 m)	

*Using 2 wire motor common

- Notes:**
- Distance (A) from control to pan/tilt is the same as distance from relay box to pan/tilt.
 - Maximum operating distance can be extended by using a low voltage control (24 VAC) and a relay box. Distance (B) from control to relay box is the same for all applications.
 - Distances are calculated with both motors (pan and tilt) running and assuming a 10% voltage drop in the cable.

MECHANICAL

Pan	0-355° movement in horizontal plane
Speed	6°/sec ±1°
Torque	50 ft-lb with specified voltage
Tilt	±90° movement in vertical plane
Speed	3°/sec ±0.5°
Maximum Load	100 lb (45.4 kg) at 5" (12.7 cm) from tilt table surface to center of gravity
Gearing	Adjustable worm-gear final drive
Bearings	
Pan	Heavy-duty ball bearings
Tilt	Oilite bronze bushing
Braking	Mechanical
Duty cycle	50% duty cycle; 30 minute rating

GENERAL

Construction	Aluminum casting and plate; all internal parts corrosion protected
Finish	Gray polyester powder coat
Environment	Indoor/outdoor; -10° to 120°F (-23° to 49°C)
Unit Weight	54 lb (24.5 kg)
Shipping Weight	59 lb (26.7 kg)

CERTIFICATIONS/RATINGS

- UL Listed (except PT1250P/220)
- Meets NEMA Type 3R standards

RECOMMENDED CONTROLS

Coaxitron or Matrix	See individual specification sheets for information. Preset pan/tilt must be used with Coaxitron or Matrix control with PP capability and preset receiver.
MPTAZ Series	Desktop control (PTZ) with auto/random scan for 120/24 VAC pan/tilts.
RB115	Relay box for 120 VAC pan/tilts. Extends operating distance (control to relay box). Use only with MPT24DT or MPTAZ24DT low voltage controls.

RECOMMENDED ENCLOSURES

EH5700 Series	Environmental enclosure, large.
---------------	---------------------------------

RECOMMENDED MOUNTS

PA2010	Adapter plate; required when using WM2000
PM2000, PM2010	Ceiling/pedestal mount; maximum load 125 lb (56.7 kg)
ST1	Support strut for WM2000/PM2000/PM2010; increases maximum load
WM2000	Wall mount; use with PA2010 adapter and ST1 support strut
WM3026	Wall mount with adjustable head; maximum load 300 lb (136 kg)

ACCESSORIES

LL27 Series	Low light infrared illuminator
-------------	--------------------------------



Pelco Worldwide Headquarters:
3500 Pelco Way, Clovis, California 93612-5699 USA
USA & Canada Tel: (800) 289-9100 • FAX (800) 289-9150
International Tel: (559) 292-1981 • FAX (559) 348-1120
www.pelco.com

Pelco and the Pelco logo are registered trademarks of Pelco.
Specifications subject to change without notice.
©Copyright 2005, Pelco. All rights reserved.